

GRADES

K-4

Kites



principles of flight

Aeronautics
Research
Mission
Directorate



Kites

Lesson Overview

In this lesson, students will learn about position and motion of object, changes in earth and sky, abilities to distinguish between natural objects and objects made by humans, and abilities of technological design as they learn about one of the forces of nature and how it impacts objects in the air. The force of nature we will focus on is “air” or “wind.” Students will comment on how the wind acts on various objects. They will make observations based on what they see and learn how to identify the direction the wind is blowing. Students will also learn to gauge approximately how fast the wind is moving based on objects in nature and their movements. Students will learn about the Beaufort Wind Scale and why it was developed. Students will be able to make educated estimates about how many knots the wind is moving outside by observing objects in nature and their movements.

Students will follow directions to create simple kites and draw conclusions from their understanding of the power of wind as it applies to the activity of flying. By understanding that animals and humans can use nature’s power of wind to accomplish different activities, students will learn how the forces of nature can impact our daily lives.

Objectives

Students will:

1. Understand that wind is a force of nature.
2. Explain how wind impacts objects in the air.
3. Be able to identify the direction the wind is blowing.
4. Be able to identify approximately how fast the wind is moving.
5. Create simple kites.
6. Identify man-made objects that fly.
7. Identify objects in nature that fly.
8. Identify different shapes of kites.
9. Identify different types of kites.

Materials:

In the Box

Fan
 Balloons
 Large ball of string
 Scissors
 Store-bought kites
 Clear tape
 Glue sticks
 Crayons
 Colored pencils
 Markers
 Small foam plates (dessert size)
 Unsharpened pencils
 Paper-hole puncher
 Fan (optional)
 Small plastic bags
 Large plastic bags
 Ruler
 Compass
 Stencils

Provided by User

Quarter
 Pre-cut shapes for students (quantity based on group size)
 Paper towel dowels

GRADES

K-4

Time Requirements: 2 ¾ - 4 hours

Background

Kites have dazzled our skies for over 2,000 years. Using silk and bamboo, the Chinese were the first to fly kites. The Japanese flew kites mostly for religious reasons. Often times kites were fitted with whistles or strings in order to make musical sounds while in flight. Kites were decorated with mythological themes or legendary figures to show respect as well. It was not until the 18th century that kites were used and taken seriously in Europe. Kites became more than just important religious symbols; they had become instruments of scientific research. The "Golden Age of Kiting," is said to have occurred from 1860 to 1910. Kites were used for meteorology, aeronautics, wireless communication and photography. After the Wright Brothers flew their "Wright Flyer," in 1903, interest in kites diminished and by WWII, kites had become a toy used primarily for recreation.



Img. 1 Children flying kites



Img. 2 Cody manlifter

While we are not exactly sure when the first kite was flown, it has been documented that Chinese General Han Hsin flew a kite over the wall of a city he was attacking around the year 200 B.C. He wanted to measure how far his army would have to tunnel underneath the city in order to reach past its defenses. Another story recounts that nearly 300 years ago a thief used a large kite to carry himself to the top of a castle so he could steal a golden statue from the roof.

Kites also were used to carry cameras and meteorological instruments. The British, French, Italian, and Russian armies utilized kites during World War I for immediate observations and signaling. During World War II however, the United States Navy found other uses for kites. For example, kites were flown to prevent airplanes from flying too low over targets, used for target practice, and if a pilot was lost at sea they would raise a kite so they could be found.

Samuel Cody came to the attention of the English War Office after he crossed the English Channel in a boat drawn by a kite. He continued his experiments with passenger kites and lifted a person to a new record high of 1600 feet. Cody's design was adopted in 1906, and his war kites were used for observation until they were later replaced by aircraft.

Eventually Cody's interest turned to gliders, which was based largely on his kite designs. Cody and his kite had a profound impact on the British Army. He became the chief instructor in kiting at the balloon school in Aldershot, England. It was also during this period of time that Cody built a motorized kite. He wanted to develop one of his motorized kites into a man-carrying airplane. However, the British Army was more interested in airships during 1907 than they were in airplanes.

Perhaps one of the most interesting kites in history was one constructed by Alexander Graham Bell. His kite was specifically designed to carry people. Bell believed that the best type of kite to do this was a tetrahedron kite. A tetrahedron is essentially a triangular pyramid: a three-dimensional figure with four equilateral triangles.

His first kite, called the Frost King, was comprised of 256 cells or tetrahedrons. Bell was determined to build a kite that could carry a man, and therefore, increased his tetrahedron kite structure from 256 cells to 1300. In 1907, Bell built another kite which he called the Cygnet. It was the first kite he had ever designed, manned with a person and then flew. The kite contained 3,393 cells and had floats attached to the bottom so it could land on water. Just imagine how it must have felt to fly that kite! Graham's kite flew for 7 minutes and went as high as 168 feet.

When we think of kites today, we usually think of them as recreational. For example, something a family would do at a park on a windy day. Interestingly, kites have had many useful purposes in the past and continue to, even to this day. Fisherman today use something called a "bobber," to help them determine when a fish bites their line.



Img. 4 Bell's tetrahedron kite

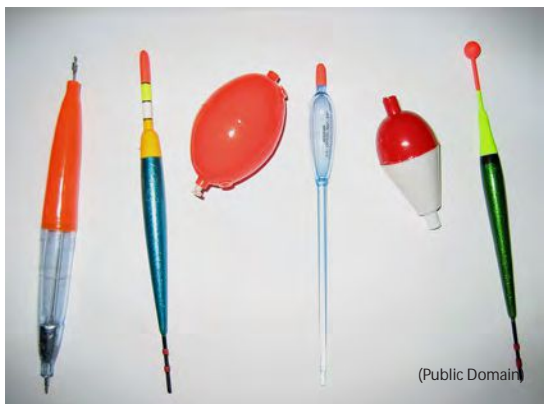

Img. 5 Fishing bobbers

Imagine fishing from the beach; what can a kite do that a regular fishing pole could not? The kite can take a fishing line far offshore where larger fish are located. The normal distance a fisherman can cast his pole cannot reach the same distance that a kite could be flown. Long-ago Chinese fishermen actually used kites in the same manner. They would tie fishing line to the end of their kite, and when the fish took the bait, the kite would move.



Img. 3 Samuel Cody

Today, farmers use scarecrows to keep birds away that would eat their crops. Chinese farmers would use kites in their fields in much the same manner. Kites were also used for testing the wind, measuring distances, and signaling. During WWII, kites were used by Navy anti-aircraft gunners for target practice. The military used kites because they



Img. 6 Kite shing

maneuver in the air in a similar fashion to the fighter aircraft that the gunners were responsible for defending their battleships against. Kites are still used today by the military for target practice. Scientists use kites as well to conduct experiments and to gather meteorological readings. Competitions are held for stunt kites and for recreational use. Their design has expanded beyond the known diamond and box kites.

There are many types of kites, and over the years the materials used to build kites has changed. Materials have included silk, bamboo, string, plastic, nylon, wood and more. NASA has classified five different types of kites. Reviewing the different kites will help you as the teacher, and will help prepare your students for this lesson. The five types of kites discussed in this lesson are the Winged Box, the Sled, the Delta, the Box Kite, and finally the Diamond.



Img. 7 Scarecrow

All kites must be lightweight and strong to endure powerful winds. A solid frame made usually of wood or plastic serves as the base of the kite, while paper, plastic, or cloth serve as the kite's skin. Kites will range in abilities based on

their construction. Some kites are very stable while others are extremely maneuverable. Kites also can soar to high altitudes and others can perform magnificent stunts.



Img. 8 A modern kite

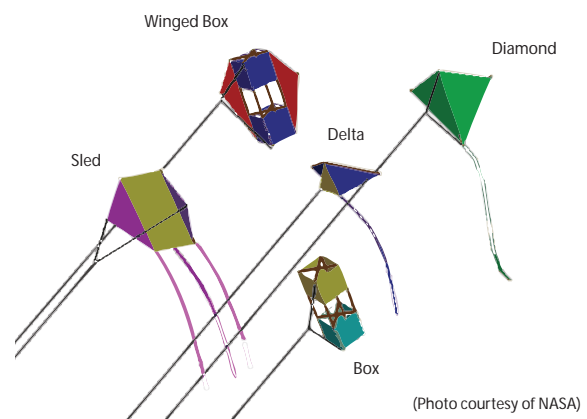

Img. 9 Types of kites



Img. 10 Leonardo da Vinci's Ornithopter

Many of us have seen the famous picture of Benjamin Franklin and his kite (Img. 5). However, Franklin was not the first one to use kites in a scientific fashion. During the late 1400s, Leonardo da Vinci began to study flight by observing birds. Later he flew kites which inspired him to design flying machines.



Img. 11 Benjamin Franklin flying his kite

In 1899, the Wright Brothers built a bi-plane kite, which was the kite that was used to invent wing warping, a significant discovery. The Wright Brothers gained further insight about how to create the world's first working flying machine by learning that the wings of a kite could be twisted or warped. By

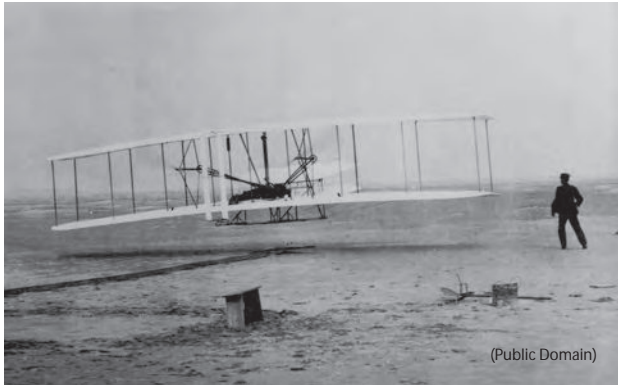

Img. 12 Wright kite

finding a way to twist the wings, it gave them greater control of their kite. This led to their creation of gliders, which then led to their invention of the Wright Flyer

Created by Gertrude and Francis Rogallo in 1948, the Rogallo wing or parawing is a flexible type of airfoil. This flexible wing was considered by NASA to be an alternate recovery system for the Gemini space capsule. Composed of two partial conic surfaces, both cones point forward and is considered to be a simple and inexpensive

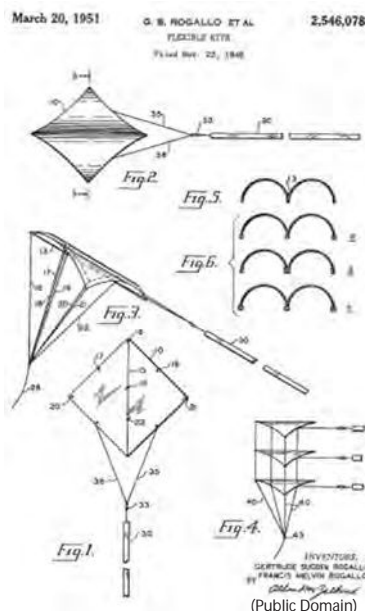

Img. 14 Rogallo patent

flying wing that has many remarkable properties. The Rogallo wing itself cannot be classified as a powered aircraft glider or kite. The way in which the wing is attached and manipulated does not allow it to be classified as a kite or glider. It has been used in toy kites, spacecraft parachutes, ultralight powered air craft, gliders, and in sport parachutes. What makes the wings so special is that it is designed to bend and flex in the wind. This provides favorable dynamics which can be compared to a spring suspension in an automobile.

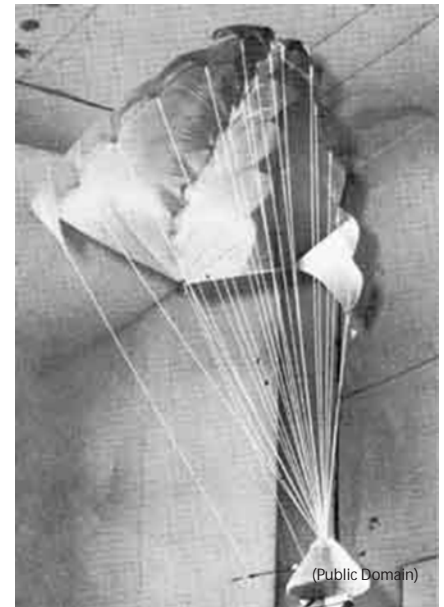

Img. 13 Rogallo's wing

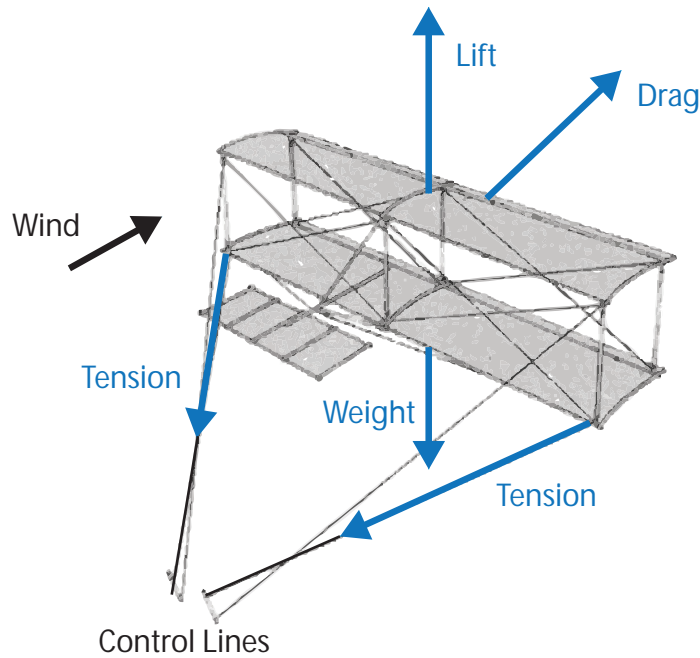

(Photo courtesy of NASA)

Img. 15 Forces on a kite

Similar to airplanes, kites are affected by wind and the four forces of flight; weight or gravity, lift, drag, and thrust. When a kite flies, it overcomes the force of gravity because the force of the wing and its pressure on the kite's surfaces helps to push it upward. Since kites are heavier than air, they weigh more than the volume of the air they displace. The air pressure increases as the wind hits the face or front surface of the kite.

The air blowing onto the face of the kite, traveling around its sides and down the kite's backside creates a low pressure area above the kite. When the wind hits the front of the kite, the wind is deflected downward, and there is a force in the opposite direction, which pushes the kite upward. This action depicts Newton's Third Law of Motion, which states that for every action there is an equal and opposite reaction. The shape of the kite affects the distribution of the aerodynamic forces. All of these things come into play when flying a kite, whether for fun or for scientific experimentation.



Without wind, it is very hard to fly a kite. Some days the wind is too calm for a kite to take flight or to conduct kite experiments. Other times flying a kite would not be optimal, for example, during a thunderstorm. Today, we have a variety of meteorological instruments that can measure the wind, weather, and temperature. However, prior to the 1800s, we had to guess the wind speed. That changed when Sir Francis Beaufort, who was serving on the HMS Woolwich in 1805, devised a scale to measure wind speed based on his observations of nature and man-made objects. His sea-based wind observation system, now referred to as the Beaufort Scale (Fig. 1), standardized the measurement of wind using a 0-12 rating scale. The ratings were based on the estimated wind knots through observation of what could be seen from the ocean to trees on land. Eventually, the scale was adapted from sea to land which is what we will learn about in this lesson.

Using the Beaufort scale while at sea is a tool that most boat captains still use today. In addition, the BBC radio in the United Kingdom uses it for shipping forecasts, as does the Irish Meteorological Service. China, Greece, Hong Kong and Taiwan also use this scale.

Humans have always been fascinated with flying. Before we could wrap our heads around something like Leonardo da Vinci's Orinthopter, we managed to fly high in the sky aboard man-carrying kites. Kites have dazzled our skies and our imagination for over 2,000 years. We have learned that kites were made of different materials and that over the years these materials have become more advanced as technology in construction has improved. The creativity of those who have been involved in designing kites is remarkable. Their purposes range from fishing, to farming, to military intelligence and scientific experiments which show just how diverse kites have been and continue to be to this day.

Fig. 1 The Beaufort scale

Beaufort number	Description	Wind speed	Wave height	Sea conditions	Land conditions
0	Calm	< 1 km/h (< 0.3 m/s)	0 m	Flat.	Calm. Smoke rises vertically.
		< 1 mph			
		< 1 kn	0 ft		
		< 0.3 m/s			
1	Light air	1.1–5.5 km/h (0.3-2 m/s)	0–0.2 m	Ripples without crests.	Smoke drift indicates wind direction and wind vanes cease moving.
		1–3 mph	0–1 ft		
		1–2 kn			
		0.3–1.5 m/s			
2	Light breeze	5.6–11 km/h (2-3 m/s)	0.2–0.5 m	Small wavelets. Crests of glassy appearance, not breaking.	Wind felt on exposed skin. Leaves rustle and wind vanes begin to move.
		4–7 mph			
		3–6 kn	1–2 ft		
		1.6–3.4 m/s			
3	Gentle breeze	12–19 km/h (3-5 m/s)	0.5–1 m	Large wavelets. Crests begin to break; scattered whitecaps.	Leaves and small twigs constantly moving, light ags extended.
		8–12 mph			
		7–10 kn	2–3.5 ft		
		3.4–5.4 m/s			
4	Moderate breeze	20–28 km/h (6-8 m/s)	1–2 m	Small waves with breaking crests. Fairly frequent whitecaps.	Dust and loose paper raised. Small branches begin to move.
		13–17 mph			
		11–15 kn	3.5–6 ft		
		5.5–7.9 m/s			
5	Fresh breeze	29–38 km/h (8.1-10.6 m/s)	2–3 m	Moderate waves of some length. Many whitecaps. Small amounts of spray.	Branches of a moderate size move. Small trees in leaf begin to sway.
		18–24 mph			
		16–20 kn	6–9 ft		
		8.0–10.7 m/s			
6	Strong breeze	39–49 km/h (10.8-13.6 m/s)	3–4 m	Long waves begin to form. White foam crests are very frequent. Some airborne spray is present.	Large branches in motion. Whistling heard in overhead wires. Umbrella use becomes difficult. Empty plastic garbage cans tip over.
		25–30 mph			
		21–26 kn	9–13 ft		
		10.8–13.8 m/s			

Fig. 1 The Beaufort scale (cont.)

Beaufort number	Description	Wind speed	Wave height	Sea conditions	Land conditions
7	High wind, Moderate gale, Near gale	50–61 km/h (13.9-16.9 m/s)	4–5.5 m	Sea heaps up. Some foam from breaking waves is blown into streaks along wind direction. Moderate amounts of airborne spray.	Whole trees in motion. Effort needed to walk against the wind.
		31–38 mph			
		27–33 kn	13–19 ft		
		13.9–17.1 m/s			
8	Gale, Fresh gale	62–74 km/h (17.2-20.6 m/s)	5.5–7.5 m	Moderately high waves with breaking crests forming spindrift. Well-marked streaks of foam are blown along wind direction. Considerable airborne spray.	Some twigs broken from trees. Cars veer on road. Progress on foot is seriously impeded.
		39–46 mph			
		34–40 kn	18–25 ft		
		17.2–20.7 m/s			
9	Strong gale	75–88 km/h (20.8-24.4 m/s)	7–10 m	High waves whose crests sometimes roll over. Dense foam is blown along wind direction. Large amounts of airborne spray may begin to reduce visibility.	Some branches break off trees, and some small trees blow over. Construction/temporary signs and barricades blow over.
		47–54 mph			
		41–47 kn	23–32 ft		
		20.8–24.4 m/s			
10	Storm Whole gale	89–102 km/h (24.7-28.3 m/s)	9–12.5 m	Very high waves with overhanging crests. Large patches of foam from wave crests give the sea a white appearance. Considerable tumbling of waves with heavy impact. Large amounts of airborne spray reduce visibility.	Trees are broken off or uprooted, saplings bent and deformed. Poorly attached asphalt shingles and shingles in poor condition peel off roofs.
		55–63 mph			
		48–55 kn	29–41 ft		
		24.5–28.4 m/s			
11	Violent storm	103–117 km/h (28.6-32.5 m/s)	11.5–16 m	Exceptionally high waves. Very large patches of foam, driven before the wind, cover much of the sea surface. Very large amounts of airborne spray severely reduce visibility.	Widespread damage to vegetation. Many roofing surfaces are damaged; asphalt tiles that have curled up and/or fractured due to age may break away completely.
		64–72 mph			
		56–63 kn	37–52 ft		
		28.5–32.6 m/s			
12	Hurricane force	118 km/h (32.8 m/s)	14 m	Huge waves. Sea is completely white with foam and spray. Air is filled with driving spray, greatly reducing visibility.	Very widespread damage to vegetation. Some windows may break; mobile homes and poorly constructed sheds and barns are damaged. Debris may be hurled about.
		73 mph			
		64 kn	46 ft		
		32.7 m/s			

Activity 1a

Diamond Kite Construction 101

GRADES

K-2

Time Requirements: 90 minutes

Materials:

In the Box

- Kite Template on Legal Size paper (1 per student)
- Scotch Tape (enough for a class, 2-3 rolls)
- Large lightweight paper bag from supermarket used to pack groceries (1 per student)
- Writing implement for purpose of tracing on paper bag (1 per student)
- Scissors (1 per student)
- Non-flexible straws at least 8 inches long (4 per student)
- Ribbon (2-3 inches wide and enough for at least 12 feet per student)
- Yard stick or tape for measuring purposes (2-4 for the class)
- Pre-cut string for kite flying purposes (25-30 feet per student)
- Unsharpened pencils or firm elongated item to wrap kite flying string (1 per student)

Provided by User

None

Worksheets

None

Objective:

Through experimentation, students will:

1. Understand that wind is a force of nature.
2. Explain how wind impacts objects in the air.
3. Use prior knowledge and new information gained through the activity to construct their own diamond kite.

Activity Overview:

Students will create and fly their diamond kite by following the directions and using the materials provided.

Activity: Preparation for Teacher (or skillful students working in pairs, i.e., 3rd or 4th graders):

Additional help will be needed to assist the children with building their kites, i.e., older students or other adults.

Be sure it is a windy day to test-fly the kites. Otherwise, students will be disappointed when their kites do not fly due to lack of wind. Have students stand with their back to the wind before releasing the kite.

It is recommended for the younger students that the teachers not only prepare the kite sails, but cut pieces of pre-measured tape, string, and ribbon as well.

Preparation of kite template on legal size paper:

1. Copy the number of kite templates per number of students in your class.
2. Either the teacher or student cuts along the two black lines from corner edge to corner edge of the kite template copied on legal size paper.

Preparation of four 8-inch straws as kite-frame structure:

1. Take one straw and pinch one end. Insert that pinched end into a second straw so that they overlap 1 ½ inches.
2. Do the same with the other two straws so they, too, overlap 1 ½ inches.
3. Set aside.

Reference Materials

Kite Template
(Figure 2)

Key Terms:

- Bridle
- Cover
- Flying line
- Kite frame
- Spar
- Spine
- Tail

Preparation of four 8-inch straws as kite-frame structure:

1. Open the empty paper grocery bag and place it upright on a hard surface.
2. Choose any corner of the bottom of the bag, and with your scissors punch a hole in that corner.
3. Using that hole as your starting point, cut around the edges and cut out the bottom of the bag.
4. Flatten the bag on a hard surface along one of the creases.
5. Place one kite template (Fig. 2) with line A-C along each of the folded creases.
(2 kite templates should fit on each creased side of the grocery bag.)
6. Trace the kite templates.

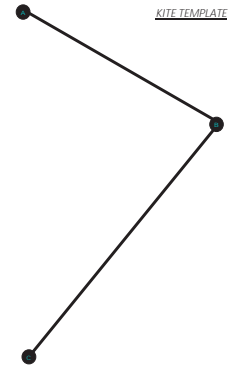
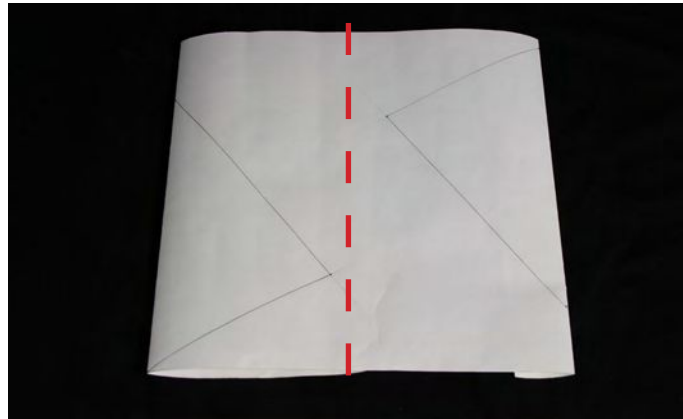
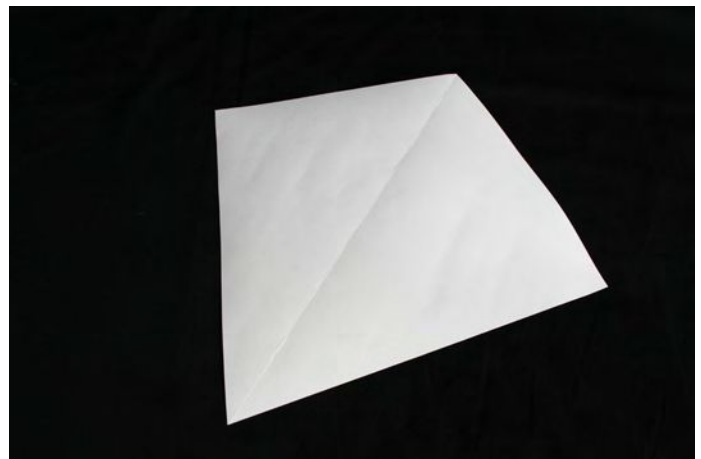

Fig. 2 Kite Template



7. Cut the paper bag vertically through the center to separate the two traced-kite templates.
(A teacher can cut the bag or one student of the paired 3rd or 4th graders can cut the bag to provide two kites.)

8. Cut out the templates and unfold to reveal a diamond-shaped kite.



9. OPTIONAL – decorate/color kite.

Kite Construction:

1. Place one set of "joined" straws vertically across the kite from one point to the other.
2. Tape the straw ends onto the top and bottom "corner" ends of the paper kite.
3. Place the other set of "joined" straws horizontally along the kite from one point to the other.
4. Tape the straw onto the other "corner" ends of the paper kite.
5. Cut a piece of ribbon measuring 60 inches in length.
6. Tie one end of the ribbon to the end of the vertical kite dowel.

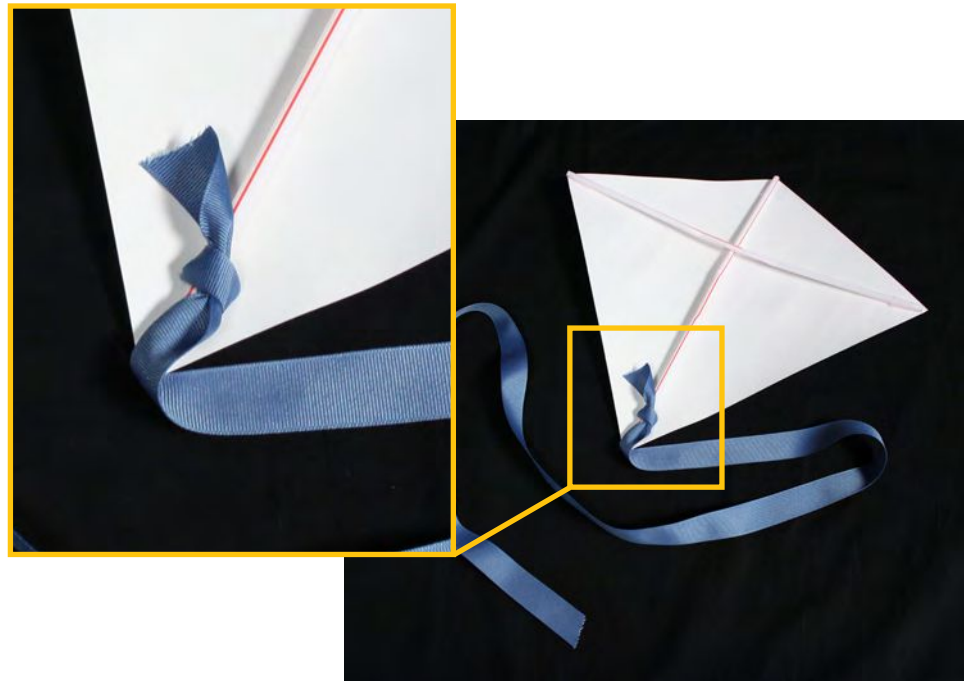

7. Measure and cut 25 feet of string for the kite.
8. Take one end of the 25 feet of string and tie it with a double knot where the two straws cross in the center of the kite.

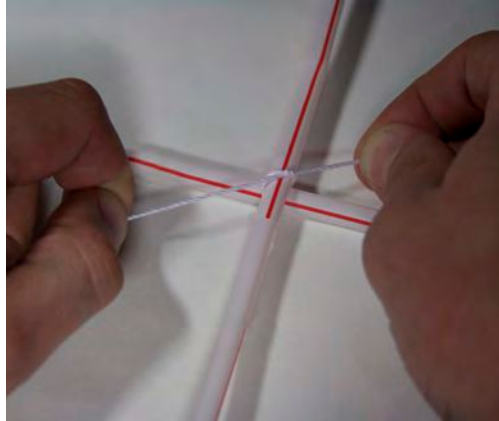

9. Tie the other end of the 25 feet of string around the un-sharpened pencil.
10. Take a piece of scotch tape and secure the knot you just made to the pencil.
11. Wrap the string around the pencil until there is about 3 to 4 feet left.



12. Your kite is prepared for flight!

Ensure it is a windy day to fly the kite and students have their back to the wind before releasing the kite!

NATIONAL SCIENCE STANDARDS K-4

SCIENCE AS INQUIRY

- Abilities necessary to do scientific inquiry
- Understanding about scientific inquiry

PHYSICAL SCIENCE

- Property of objects and materials
- Position and motion of objects
- Science as human endeavor

SCIENCE AND TECHNOLOGY

- Abilities of technological design
- Understanding about science and technology

NATIONAL MATH STANDARDS K-4

MEASUREMENT

- Understand how to measure using nonstandard and standard units
- Select an appropriate unit and tool for the attribute being measured
- Understand the need for measuring with standard units and become familiar with standard units in the customary and metric systems;
- Use tools to measure
- Select and apply appropriate standard units and tools to measure length, area, volume, weight, time, temperature, and the size of angles

Activity 1b

Diamond Kite Construction 101

GRADES

3-4

Time Requirements: 2 hours

Materials:

In the Box

- Kite string
- Scotch Tape and glue
- Knife or small saw)
- Sheet of strong paper or garbage bag (102 cm x 102 cm) (40 in x 40 in)
- 2 strong, straight wooden sticks (wooden doweling) 90 cm (35 in) and 102 cm (40 in)
- Different colored markers, paint or crayons to decorate your kite
- Strips of cloth

Provided by User

None

Worksheets

None

Reference Materials

None

Key Terms:

- Bridle
- Cover
- Flying line
- Kite frame
- Spar
- Spine
- Tail

Objective:

Through experimentation, students will:

1. Build a diamond kite and fly it.

Activity Overview:

Students will build and fly their own basic diamond kite by following the directions and using the materials provided.

Activity: Preparation for Teacher

1. **The first thing to do is to make a cross with the two sticks.** The 102 cm (40 in) stick is the spine and the 90 cm (35 in) stick is the spar. It is important to ensure that both sides of the cross piece are equal in length.
2. **Next, tie the two sticks together with string where the two sticks cross.** Make sure the sticks are securely lashed together. A dab of glue can also be used with the string to ensure a stronger bond between the sticks. Tie the two sticks together with the string in such a way as to make sure that they are at right angles to each other.



- Use a knife or small saw to cut a V shaped notch at each end of both sticks. The notch must be large enough to allow for the string to fit into it. Then cut a piece of string to stretch around each end of the sticks.

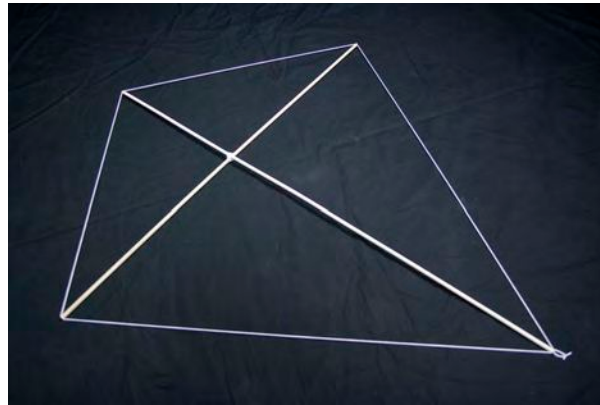

When the string has been stretched around the kite make a loop and tie both ends of the string together. The string should be taut, but not so tightly stretched as to warp the sticks. This is the kite frame.

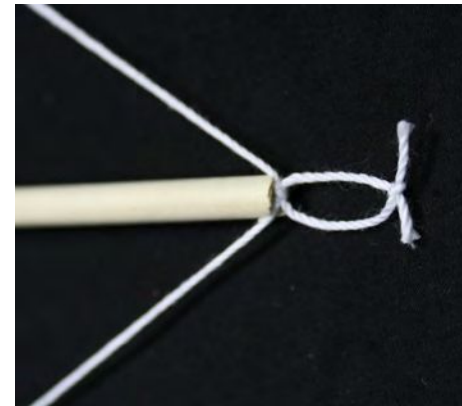

- Lay the kite frame flat and place the stick frame face down on top of the paper or garbage bag (102 cm x 102 cm) (40 in x 40 in). Carefully, cut around the kite frame and do not cut the string. Leave about 2-3 cm (3/4 in – 1 in) for a margin beyond the string. Fold these edges over the string frame and tape or glue it down so that the material is tight.

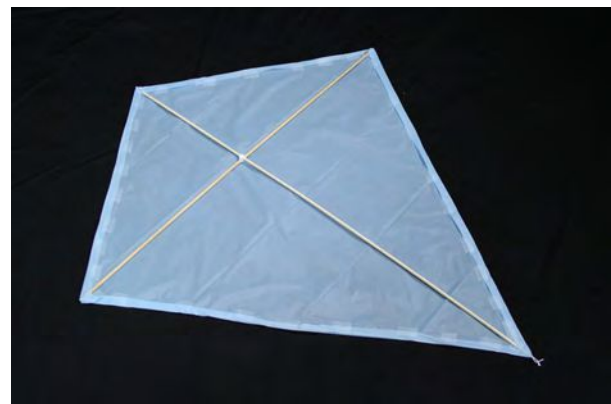

- Next, cut a piece of string about 125 cm (50 in) long. On the front side of the kite, tie one end of the string on the top of the spine and then tie the other end to the bottom of the spine.

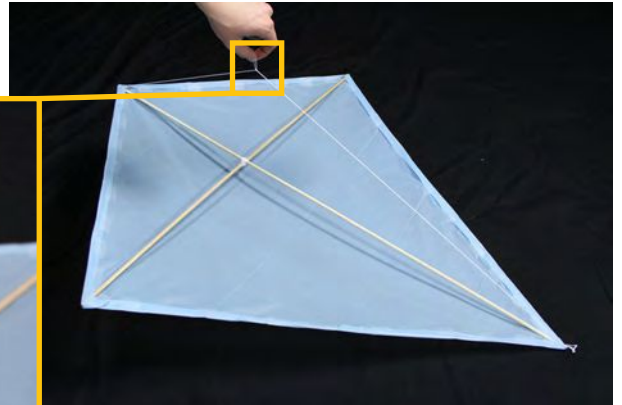
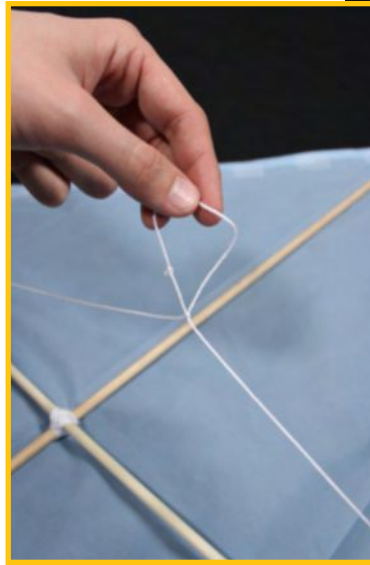

Tie a small loop in the string just above the intersection of the spine and spar. This is the kite's bridle. The string to fly the kite is to be attached to the loop in the bridle.

- Make a tail by tying small pieces of cloth together. Attach the tail to the loop at the bottom of the kite.



Further suggestions

- Sometimes it is helpful to put a slight bow in the kite. To do this stretch a piece of string from one end of the spar to the other end and gently pull to create a bow in the kite and then tie the string to one end of the spar.*
- NEVER FLY A KITE NEAR A POWER LINE**
- NEVER FLY A KITE IN A THUNDERSTORM**

Experiment with your kite and have fun!

NATIONAL SCIENCE STANDARDS K-4

SCIENCE AS INQUIRY

- Abilities necessary to do scientific inquiry
- Understanding about scientific inquiry

PHYSICAL SCIENCE

- Property of objects and materials
- Position and motion of objects
- Science as human endeavor

SCIENCE AND TECHNOLOGY

- Abilities of technological design
- Understanding about science and technology

NATIONAL MATH STANDARDS K-4

MEASUREMENT

- Understand how to measure using nonstandard and standard units
- Select an appropriate unit and tool for the attribute being measured
- Understand the need for measuring with standard units and become familiar with standard units in the customary and metric systems;
- Use tools to measure
- Select and apply appropriate standard units and tools to measure length, area, volume, weight, time, temperature, and the size of angles

Activity 2

Wind, Shapes, and Kites - Oh My!

GRADES

K-2

Time Requirements: 75 minutes

Materials:In the Box

Balloons
 Large ball of string
 Scissors
 Store-bought kites
 Clear tape
 Glue sticks
 Crayons
 Colored pencils
 Markers
 Small foam plates (dessert size)
 Unsharpened pencils
 Paper-hole puncher
 Fan (optional)

Provided by User

Pre-cut shapes for students (quantity based on group size)

Worksheets

Wind Observation
 (Worksheet 1)

Reference Materials

None

Objective:

Through experimentation, students will:

1. Understand that wind is a force of nature.
2. Explain how wind impacts objects in the air
3. Be able to identify direction wind is blowing
4. Be able to identify approximately how fast the wind is moving
5. Identify man-made objects that fly
6. Identify objects in nature that fly

Activity Overview:

Through observation and identification, students will learn about properties of objects and materials, position and motion of objects, abilities of technological design, and science as a human endeavor as they learn to recognize the direction and force of wind. They will discuss their observations as they relate to the force of wind and how it affects objects. Students will test materials and designs, creating kites from a set of supplies based on what they believe will fly the best.

Activity:

1. **Spend about 5 minutes brainstorming with your students.** Ask them to identify man-made objects and entities in nature that fly. *(Answers will include items such as planes, birds, bats, owls, jets and helicopters, etc.)*
2. **Ask the students why we can stay on the ground when we walk and we don't float away.** *(Answers should include weight or gravity.)*
3. **Now ask students what the man-made objects and entities in nature need to fly.** *(Answers could include wings, engines, and lift).* The students need to focus on lift. *Explain to students that lift is a force of flight that helps objects get off the ground. Tell the students that they are going to perform an experiment to show lift and gravity.*

Key Terms:

Beaufort Scale

Gravity

Kite

Observation

Ornithopter

Wind

4. **Ask two students to volunteer.** Give one student a balloon that has been blown up and give one student a pencil. Ask the students what item they believe will hit the ground first, the balloon or the pencil. After you have discussed what they believe will happen have the two students extend their arms out and drop the balloon and pencil at the same time. Have the class count to three together. (3-2-1 drop).
5. **Explain to the students that the experiment they just performed showed us about gravity and that gravity is a force of flight.** Another force of flight they will be learning about is lift. Ask the students what they think the word lift means. *Explain that lift is the opposite of gravity. Gravity is what keeps us on the ground and lift is what helps objects whether man-made like kites or things in nature like birds take off into the air and stay airborne.*
6. **Next, show the students the store-bought kites.** Ask them what shapes they see that are used in the store-bought kites. (*Shapes should include triangles, squares, rectangles, circles and pyramids*).
7. **Each student needs to have a group of shapes in order to create a template for their kite.** These shapes should include triangles, squares, rectangles, circles, pyramids, and trapezoids. Tell the students they need to assemble these shapes into their own unique design using tape or glue sticks. Also, students can decorate their kite with crayons, colored pencils and markers.
8. **Next, pass out a small foam plate to each student.**
9. **Let the students decorate their foam plate kites.** Once they are completed, you may need to help them assemble it. Punch two holes on either side of the plate so that they are of equal distance across on either side of the plate. Next, take the first piece of string and loop it through the hole and tie it off in a knot. Do this same step for the other hole. Now there should be two holes and two pieces of string hanging down from the plate.
10. **Next, take the two pieces of string and tie them at the bottom so they form a "v."** Take the knot and tape the knot to an unsharpened pencil they will use for their kite handle. Wrap the string around the pencil twice and tie into a double knot. The string should be secure and ready for flight.
11. **Now, the students are ready to fly their foam plate kites outside.** If there is not enough wind, you can use a fan for this step. Once the students have test-flown their kites, have them either talk to you about what they experienced (for the younger students) and/or fill out the Wind Observation Worksheet (K-2 and 3-4 students).
12. **The teacher or instructor should test fly the store-bought kites so that the students can compare and contrast their observations to the foam plate kites.** Once they have flown both sets of kites, students will need to complete the rest of the Wind Observation Worksheet.

NATIONAL SCIENCE STANDARDS K-4

SCIENCE AS INQUIRY

- Abilities necessary to do scientific inquiry
- Understanding about scientific inquiry

PHYSICAL SCIENCE

- Property of objects and materials
- Position and motion of objects

SCIENCE AND TECHNOLOGY

- Abilities of technological design
- Understanding about science and technology

Activity 3

Wind Scientists

GRADES

3-4

Time Requirements: 120 minutes

Materials:In the Box

Balloons
 Large ball of string
 Scissors
 Store-bought kites
 Fan
 Clear tape
 Glue Sticks
 Small foam plates (dessert size)
 Unsharpened pencils
 Paper-hole puncher
 Small plastic bags
 Large plastic bags
 Ruler
 Compass
 Stencils

Provided by User

Quarter
 Pre-cut shapes for students
 (quantity based on group size)
 Crayons
 Colored Pencils
 Markers
 Paper Towel Dowels

Objective:

Through experimentation, students will:

1. Understand that wind is a force of nature.
2. Explain how wind impacts objects in the air
3. Be able to identify direction wind is blowing
4. Be able to identify approximately how fast the wind is moving
5. Identify man-made objects that fly
6. Identify objects in nature that fly

Activity Overview:

Through observation and identification, students will learn about the changes in earth and sky, the abilities of technological design, and understanding about science and technology, and science as a human endeavor as they learn to recognize the direction and force of wind. They will talk about their observations as they relate to the force of wind and how it affects objects. They will create kites from a set of supplies based on what they believe will fly the best. Also, test their kite, materials and designs.

Activity:

1. **Pass out the Beaufort Scale Activity Worksheet.**
2. **Read over the Beaufort Scale Activity Worksheet with the students.** Go over each section and discuss how fast the wind is moving and what the environment looks like on the sea and on land. Ask the students if they have any questions.
3. **Explain to your students that over the course of this activity they will be going outside several times to observe the wind and to record their observations.** Students will need to take notes on what they see and hear outside and compare it to the Beaufort scale chart, indicating how fast they think the wind is blowing.
4. **Have the students go outside before they start the other kite activities.** They will be recording their first wind observation (1 of 3) on their chart. Tell them they will need to take their Wind Observation Worksheet with them so that they can estimate how fast the wind is blowing. They will also need to take their compass with them in order to determine the direction the wind is blowing.

Worksheets

Wind Observation
(Worksheet 1)

Beaufort Scale Activity
(Worksheet 2)

Kite Engineering
(Worksheet 3)

Reference Materials

Beaufort scale
(Figure 1)

Key Terms:

Beaufort Scale

Gravity

Kite

Observation

Ornithopter

Wind

Have the students use their observations and a compass to determine the direction of the wind. If the students are not able to identify the direction of the wind based on trees or smokestacks or other items in nature, have them pick up some grass from the ground and hold it above their head. Next tell them to release the grass and follow the direction that the grass blows away and use their compass to determine the direction of the wind.

5. **Ask them to come back inside and start the next phase of the activity.**
6. **Spend about 5 minutes brainstorming with your students.** Ask them to identify man-made objects and entities in nature that fly. (Answers will include items like planes, birds, bats, owls, jets and helicopters, etc.).
7. **Next ask the students why we can stay on the ground when we walk and we don't float away.** (Answers should include weight or gravity.)
8. **Now ask students what the man-made objects and entities in nature need to fly.** (Answers could include wings, engines, and lift). We need the students to focus on lift. Explain to students that lift is a force of flight that helps objects get off the ground. Tell the students that they are going to perform an experiment to show lift and gravity.
9. **Have the students gather into a circle.** Make sure you have your fan, two inflated balloons including one tied with a string and quarter for weight.
10. **Ask two students to volunteer.** Give them each a balloon, instruct them to stretch their arm out and drop the balloons at the same time on the count of three.
11. **The balloon that is weighted with the string and quarter should fall to the ground first.** Ask the students why they believed that happened. (Answers should include that the weighted balloon is heavier and gravity forced it to the ground faster.)
12. **Take the balloons and ask the students which one they believe will rise faster using only the fan.** Use the fan to send the balloons upward and suspend them there for a few seconds. Make sure the fan is underneath the balloons and pointed upward so that the fan can generate the lift necessary to keep the balloons floating in the air. (Students should conclude that the balloon that weighs less is able to get off the ground faster.)
13. **Explain to the students that this is "lift", another force of flight.**
14. **Have the students go outside to record their second wind observation using their compass and chart.** See step number four for specific instructions.
15. **Ask the students to come back inside and start the next phase of the activity.**
16. **Show your students the store-bought kites.** Ask them what shapes they see (The following shapes should be included: triangles, squares, rectangles, circles, pyramids).

17. Give the students approximately 30 minutes to create their own kite designs using the store-bought kites and any other kites presented as examples. Make sure the students fill out the Kite Engineering Student Worksheet which will help them as they build their kites.
18. After 30 minutes, students should have created their own kite by following the directions on the Kite Engineering Student Worksheet and by using the materials given in the activity. This will be the student's third and final recording of their wind observations. Have the students take their compass and their chart. Refer to step number four for further instructions.
19. Now each student should have their own kite that they built completed and ready to fly. Before the students fly their kites, ask the students to think about what makes the store-bought kites fly. *For example, is it their design? Is it the materials that were used in the construction of the kite? Does the person flying the kite have any control in the kite's flight performance? Have the teacher or instructor take the class outside so that the students can observe the teacher flying these store-bought kites.*
20. Bring the class back inside and have them prepare their kites for flight. Have the students estimate how long they think their kites will stay in the air. Students should now take their kites outside and fly them. *The teacher and/or instructor should be prepared to help students with their kites if questions or problems arise.*
21. Based on the results from the students flying their kites tell them they are allowed 10 additional minutes to make any kind of modifications to their kite in order to produce better flying results. They will need to explain what changes they made and why they made them. Make sure the students complete their kite engineering worksheet. They need to compare and contrast the store-bought kites with their own handmade kites and include suggestions for improvement to their own kite the goal is for students to understand that when something is designed and created numerous test trials are conducted to improve design and functionality.

NATIONAL SCIENCE STANDARDS K-4

SCIENCE AS INQUIRY

- Abilities necessary to do scientific inquiry
- Understanding about scientific inquiry

PHYSICAL SCIENCE

- Property of objects and materials
- Position and motion of objects

SCIENCE AND TECHNOLOGY

- Abilities of technological design
- Understanding about science and technology
- Science as a human endeavor



Reference Materials

Glossary

Beaufort scale:

The Beaufort scale named after Sir Francis Beaufort of England was created by him in 1805. This scale was developed to determine the force and velocity of wind based on what ships captains and crew observed at sea. Eventually it was translated to a land based scale. The Beaufort scale describes what the environment looks like both on the water and on land based on wind velocity.

Bridle:

The string that is attached to the kite that helps to control it and the line on which the flying line is attached

Cover:

The material that is used to cover the kite frame

Flying line:

The string that runs from the kite's bridle to the string to the person flying the kite

Gravity:

A natural force of attraction which is exerted by terrestrial bodies such as planets and moons where objects that are on or near its surface are drawn towards the center. This is why on the planet Earth objects in motion that are not kept in motion by nature or technology will fall back to the ground. It is also why human beings are able to walk on the grounds without fear of floating away.

Kite:

A light framework that ranges in shape, covered with cloth, plastic, or paper, designed to be flown in the wind at the end of a long string

Kite frame:

The joined spine and spar with the string connecting each of the ends

Observation:

To watch, take note, or document a person, place or thing

Ornithopter:

A flying machine designed by Leonardo da Vinci that was propelled through the air by flapping its wings

Spar:

The horizontal stick on the kite. It is at a right angle to the spine. To improve flight the spar is often curved or bowed.

Spine:

The vertical stick on the kite. It is usually the longest stick on the kite.

Tail:

Used on a kite to help provide balance; the tail is often made of strips of cloth or ribbons. Not all kites need a tail.

Wind:

A force of nature. A natural, perceptible motion of air that moves along the earth's surface.

SUGGESTED ADDITIONAL READINGS:

We Like Kites by Stan Berenstain

The Kite Fighters by Linda Sue Park

The Emperor and the Kite by Jane Yolen

Kite Flying by Grace Lin

Henry and the Kite Dragon by Bruce Edward Hall

SUGGESTED INTERNET SEARCHES:

Kites

History of Kites

Chinese Fishing Kites

Wright Brothers and Kites

Alexander Graham Bell's Tetrahedron Kite

Benjamin Franklin and Kite Experiment

How Kites Are Used to Generate Energy

Fig. 1 The Beaufort Scale

Beaufort number	Description	Wind speed	Wave height	Sea conditions	Land conditions
0	Calm	< 1 km/h (< 0.3 m/s)	0 m	Flat.	Calm. Smoke rises vertically.
		< 1 mph			
		< 1 kn	0 ft		
		< 0.3 m/s			
1	Light air	1.1–5.5 km/h (0.3-2 m/s)	0–0.2 m	Ripples without crests.	Smoke drift indicates wind direction and wind vanes cease moving.
		1–3 mph			
		1–2 kn	0–1 ft		
		0.3–1.5 m/s			
2	Light breeze	5.6–11 km/h (2-3 m/s)	0.2–0.5 m	Small wavelets. Crests of glassy appearance, not breaking.	Wind felt on exposed skin. Leaves rustle and wind vanes begin to move.
		4–7 mph			
		3–6 kn	1–2 ft		
		1.6–3.4 m/s			
3	Gentle breeze	12–19 km/h (3-5 m/s)	0.5–1 m	Large wavelets. Crests begin to break; scattered whitecaps.	Leaves and small twigs constantly moving, light ags extended.
		8–12 mph			
		7–10 kn	2–3.5 ft		
		3.4–5.4 m/s			
4	Moderate breeze	20–28 km/h (6-8 m/s)	1–2 m	Small waves with breaking crests. Fairly frequent whitecaps.	Dust and loose paper raised. Small branches begin to move.
		13–17 mph			
		11–15 kn	3.5–6 ft		
		5.5–7.9 m/s			
5	Fresh breeze	29–38 km/h (8.1-10.6 m/s)	2–3 m	Moderate waves of some length. Many whitecaps. Small amounts of spray.	Branches of a moderate size move. Small trees in leaf begin to sway.
		18–24 mph			
		16–20 kn	6–9 ft		
		8.0–10.7 m/s			
6	Strong breeze	39–49 km/h (10.8-13.6 m/s)	3–4 m	Long waves begin to form. White foam crests are very frequent. Some airborne spray is present.	Large branches in motion. Whistling heard in overhead wires. Umbrella use becomes difficult. Empty plastic garbage cans tip over.
		25–30 mph			
		21–26 kn	9–13 ft		
		10.8–13.8 m/s			

Fig. 1 The Beaufort Scale (cont.)

Beaufort number	Description	Wind speed	Wave height	Sea conditions	Land conditions
7	High wind, Moderate gale, Near gale	50–61 km/h (13.9-16.9 m/s)	4–5.5 m	Sea heaps up. Some foam from breaking waves is blown into streaks along wind direction. Moderate amounts of airborne spray.	Whole trees in motion. Effort needed to walk against the wind.
		31–38 mph			
		27–33 kn	13–19 ft		
		13.9–17.1 m/s			
8	Gale, Fresh gale	62–74 km/h (17.2-20.6 m/s)	5.5–7.5 m	Moderately high waves with breaking crests forming spindrift. Well-marked streaks of foam are blown along wind direction. Considerable airborne spray.	Some twigs broken from trees. Cars veer on road. Progress on foot is seriously impeded.
		39–46 mph			
		34–40 kn	18–25 ft		
		17.2–20.7 m/s			
9	Strong gale	75–88 km/h (20.8-24.4 m/s)	7–10 m	High waves whose crests sometimes roll over. Dense foam is blown along wind direction. Large amounts of airborne spray may begin to reduce visibility.	Some branches break off trees, and some small trees blow over. Construction/temporary signs and barricades blow over.
		47–54 mph			
		41–47 kn	23–32 ft		
		20.8–24.4 m/s			
10	Storm Whole gale	89–102 km/h (24.7-28.3 m/s)	9–12.5 m	Very high waves with overhanging crests. Large patches of foam from wave crests give the sea a white appearance. Considerable tumbling of waves with heavy impact. Large amounts of airborne spray reduce visibility.	Trees are broken off or uprooted, saplings bent and deformed. Poorly attached asphalt shingles and shingles in poor condition peel off roofs.
		55–63 mph			
		48–55 kn	29–41 ft		
		24.5–28.4 m/s			
11	Violent storm	103–117 km/h (28.6-32.5 m/s)	11.5–16 m	Exceptionally high waves. Very large patches of foam, driven before the wind, cover much of the sea surface. Very large amounts of airborne spray severely reduce visibility.	Widespread damage to vegetation. Many roofing surfaces are damaged; asphalt tiles that have curled up and/or fractured due to age may break away completely.
		64–72 mph			
		56–63 kn	37–52 ft		
		28.5–32.6 m/s			
12	Hurricane force	118 km/h (32.8 m/s)	14 m	Huge waves. Sea is completely white with foam and spray. Air is filled with driving spray, greatly reducing visibility.	Very widespread damage to vegetation. Some windows may break; mobile homes and poorly constructed sheds and barns are damaged. Debris may be hurled about.
		73 mph			
		64 kn	46 ft		
		32.7 m/s			

Fig. 2 Kite Template

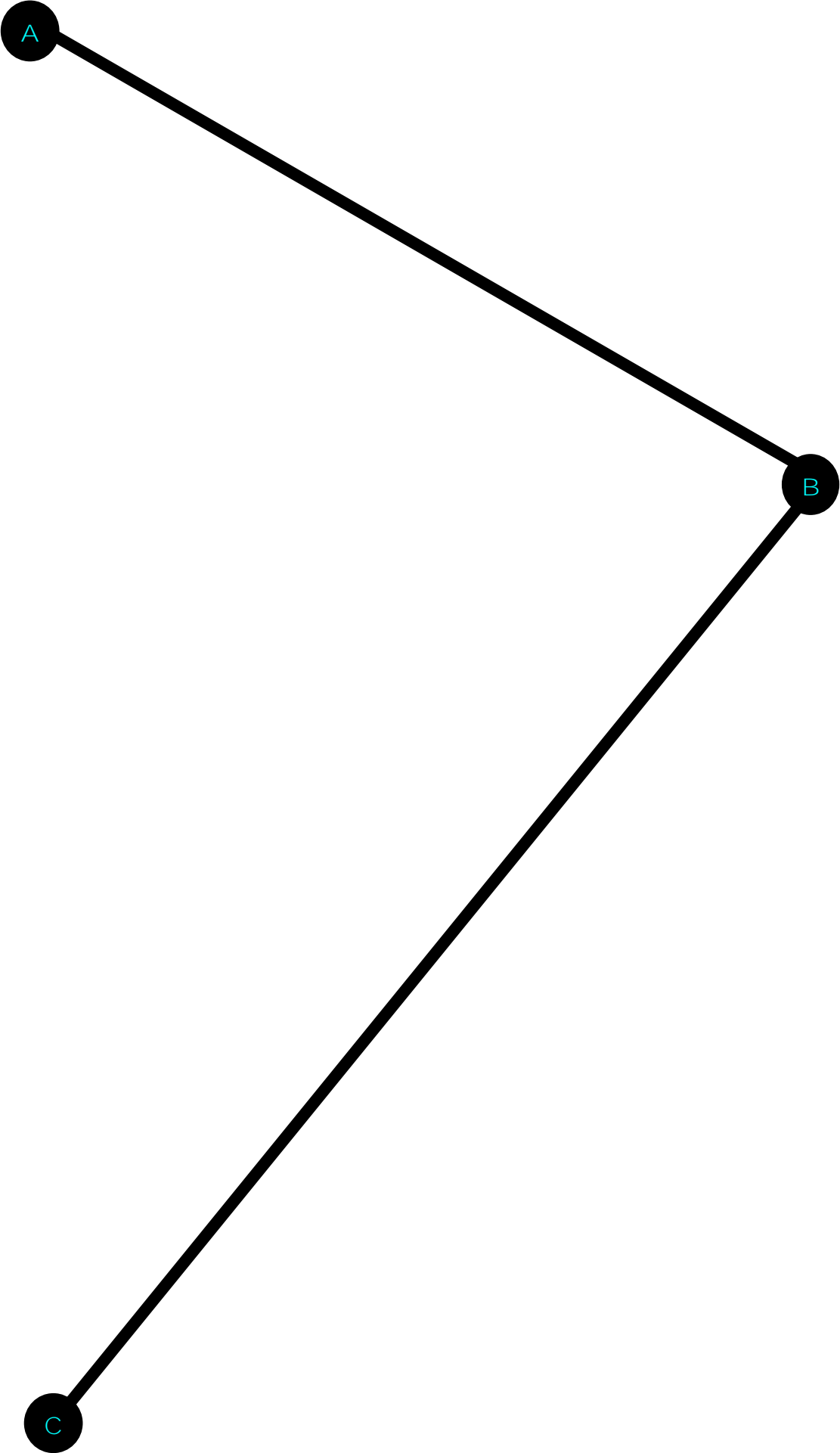



Worksheets

Worksheet 1

Wind Observation (K-2)

What happened when you flew your foam plate kite? Write your answer or draw a picture.

Did you notice any other objects in the air when you flew your kite? Write your answer or draw a picture.

What happened when you flew the store-bought kite? Write your answer or draw a picture.

Did you notice any other objects in the air when you flew the store-bought kite? Write your answer or draw a picture.

What happened when you flew your foam plate kite? Write your answer or draw a picture.

Answers will vary but students should discuss the kite flying, lift, the wind, how high it flew, how far it traveled etc.

Did you notice any other objects in the air when you flew your kite? Write your answer or draw a picture.

Answers will vary.

What happened when the teacher flew the store-bought kite? Write your answer or draw a picture.

Answers will vary but students should discuss the kite flying, lift, the wind, how high it flew, how far it traveled, etc.

Did you notice any other objects in the air when you flew the store-bought kite? Write your answer or draw a picture.

Answers will vary.

Worksheet 1

Wind Observation (3-4)

What happened when you flew your foam plate kite? Describe in detail the wind, how it interacted with your kite and any other observations. Please also include an illustration with your response below.

Did you notice any other objects in the air when you flew your kite? If so, what were they and did they behave in the same way your kite did in the air? Please also include an illustration with your response below.

What happened when you flew the store-bought kite? Describe in detail the wind, how it interacted with your kite and any other observations.

Did you notice any other objects in the air when you flew the store-bought kite? If so what were they and did they behave in the same way your kite did in the air?

What happened when you flew your foam plate kite? Describe in detail the wind, how it interacted with your kite and any other observations. Please also include an illustration with your response below.

Answers will vary but students should discuss the kite flying, lift, the wind, how high it flew, how far it traveled, etc.

Did you notice any other objects in the air when you flew your kite? If so, what were they and did they behave in the same way your kite did in the air? Please also include an illustration with your response below.

Answers will vary but students should discuss the kite flying, lift, the wind, how high it flew, how far it traveled, etc.

What happened when you flew the store-bought kite? Describe in detail the wind, how it interacted with your kite and any other observations.

Answers will vary but students should discuss the kite flying, lift, the wind, how high it flew, how far it traveled, etc.

Did you notice any other objects in the air when you flew your kite? If so, what were they and did they behave in the same way your kite did in the air?

Answers will vary but students should discuss the kite flying, lift, the wind, how high it flew, how far it traveled, etc.

Worksheet 2

Beaufort Scale Activity

Force	Wind (Knots)	WMO Classification	Appearance of Wind Effects on Land
0	Less than 1	Calm	Calm, smoke rises vertically
1	1-3	Light Air	Smoke drift indicates wind direction, still wind vanes
2	4-6	Light Breeze	Wind felt on face, leaves rustle, vanes begin to move
3	7-10	Gentle Breeze	Leaves and small twigs constantly moving, light flags extended
4	11-16	Moderate Breeze	Dust, leaves, and loose paper lifted, small tree branches move
5	17-21	Fresh Breeze	Small trees in leaf begin to sway
6	22-27	Strong Breeze	Larger tree branches moving, whistling in wires
7	28-33	Near Gale	Whole trees moving, resistance felt walking against wind
8	34-40	Gale	Whole trees in motion, resistance felt walking against wind
9	41-47	Strong Gale	Slight structural damage occurs, slate blows off roofs
10	48-55	Storm	Seldom experienced on land, trees broken or uprooted, "considerable structural damage"
11	56-63	Violent Storm	NO RANKING FOR LAND - PLEASE SKIP
12	64+	Hurricane	NO RANKING FOR LAND - PLEASE SKIP

Observation Number			
Observation Date			
Observation Time			
Direction of Wind			
Speed of Winds (Knots)			
Reasons for Wind Speed Conclusion			

Worksheet 2

Beaufort Scale Activity (Teacher Version)

Force	Wind (Knots)	WMO Classification	Appearance of Wind Effects on Land
0	Less than 1	Calm	Calm, smoke rises vertically
1	1-3	Light Air	Smoke drift indicates wind direction, still wind vanes
2	4-6	Light Breeze	Wind felt on face, leaves rustle, vanes begin to move
3	7-10	Gentle Breeze	Leaves and small twigs constantly moving, light flags extended
4	11-16	Moderate Breeze	Dust, leaves, and loose paper lifted, small tree branches move
5	17-21	Fresh Breeze	Small trees in leaf begin to sway
6	22-27	Strong Breeze	Larger tree branches moving, whistling in wires
7	28-33	Near Gale	Whole trees moving, resistance felt walking against wind
8	34-40	Gale	Whole trees in motion, resistance felt walking against wind
9	41-47	Strong Gale	Slight structural damage occurs, slate blows off roofs
10	48-55	Storm	Seldom experienced on land, trees broken or uprooted, "considerable structural damage"
11	56-63	Violent Storm	NO RANKING FOR LAND - PLEASE SKIP
12	64+	Hurricane	NO RANKING FOR LAND - PLEASE SKIP

Observation Number	Observation Date	Observation Time	Direction of Wind	Speed of Winds (Knots)	Reasons for Wind Speed Conclusion
#1	Will vary	Will vary	Based on wind direction and compass calculation	Deduction from students based on Beaufort Scale	Reasons for wind speed conclusion needs to be consistent with what is on Beaufort Scale.
#2	Will vary	Will vary	Based on wind direction and compass calculation	Deduction from students based on Beaufort Scale	Reasons for wind speed conclusion needs to be consistent with what is on Beaufort Scale.
#3	Will vary	Will vary	Based on wind direction and compass calculation	Deduction from students based on Beaufort Scale	Reasons for wind speed conclusion needs to be consistent with what is on Beaufort Scale.

Worksheet 3

Kite Engineering

Draw a design of your kite. Include the following information: dimensions, materials you will use, and reasons for your design. Please label your drawing.

After you have designed your kite you will need to build it. Once your kite is constructed, answer the following questions (include detailed observations and opinions):

1. How did your kite fly?

2. How long do you think it took your kite to get into the air?

3. How long do you estimate your kite stayed in the air?

4. How high did your kite fly?

5. If you could build your kite differently, what would you do? Explain your answer.

Worksheet 3 (cont.)

Kite Engineering (Teacher Version)

Draw a design of your kite. Include the following information: dimensions, materials you will use, and reasons for your design. Please label your drawing.

Students need to draw and label their kite. They need to list the materials they are using and label their drawing.

After you have designed your kite you will need to build it. Once your kite is constructed, answer the following questions (include detailed observations and opinions):

1. How did your kite fly?

Student answers will vary, but they should consider lessons in observation from the previous activities.

2. How long do you think it took your kite to get into the air?

Student answers will vary, but they should consider lessons in observation from the previous activities.

3. How long do you estimate your kite stayed in the air?

Student answers will vary, but they should consider lessons in observation from the previous activities.

4. How high did your kite fly?

Student answers will vary, but they should consider lessons in observation from the previous activities.

5. If you could build your kite differently, what would you do? Explain your answer..

Students should include ideas for improving their kites:

What they think they could make better on their kite and why (1-3 improvements are to be noted) If they do not believe they can make

their kite better, they need to discuss what they are curious about and what other changes they would make to experiment with

in the future.



Images

Img. 1 Children flying kites



(Public Domain)

Img. 2 Cody manlifter



(Public Domain)

Img. 3 Samuel Cody



(Public Domain)

Img. 4 Bell's tetrahedron kite

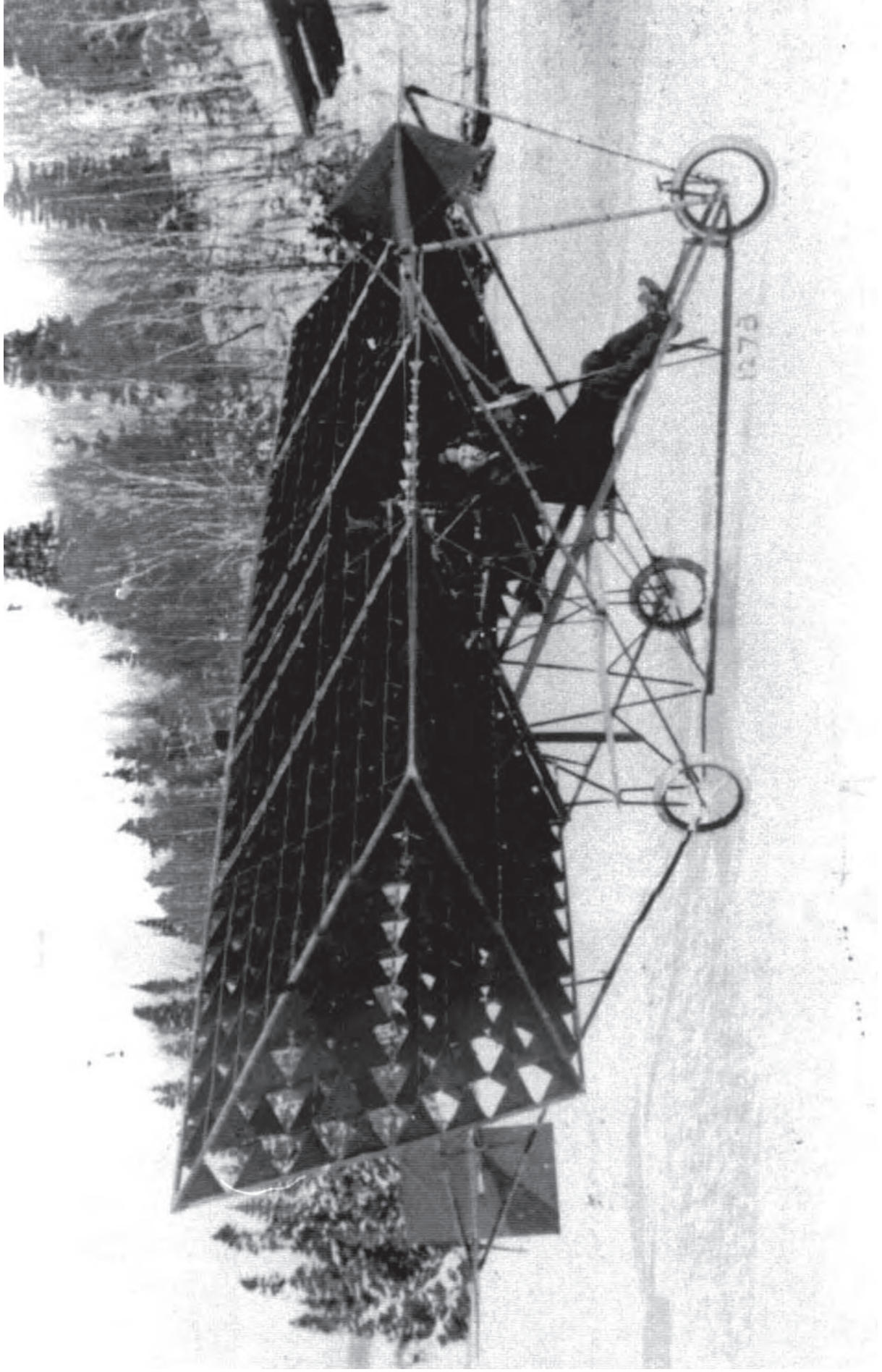

(Photo courtesy of NASA)

Img. 5 Fishing bobbers

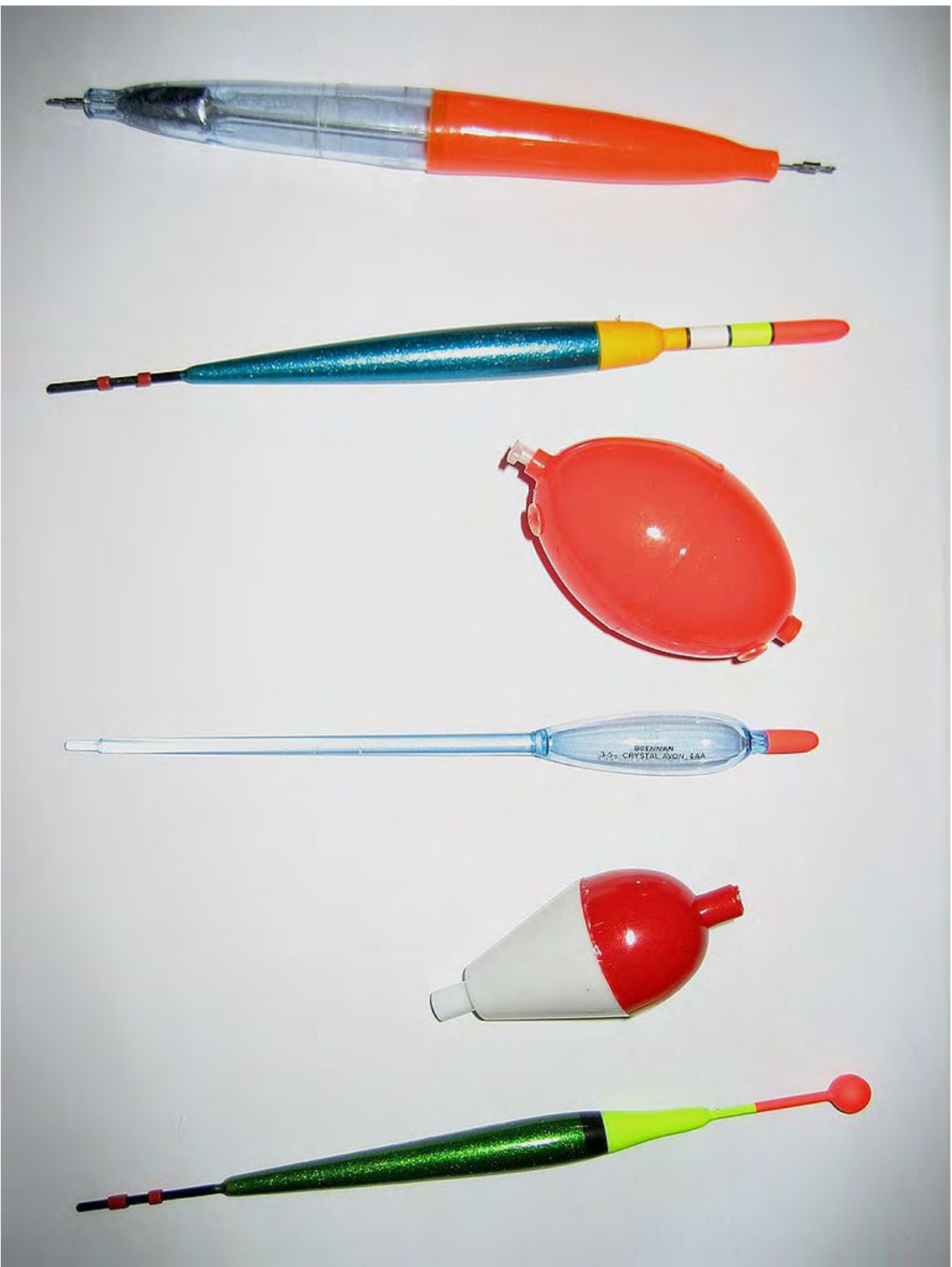

(Public Domain)

Img. 6 Kite shing



(Public Domain)

Img. 7 Scarecrow



(Public Domain)

Img. 8 A modern kite



(Photo courtesy of NASA)

Img. 9 Types of kites

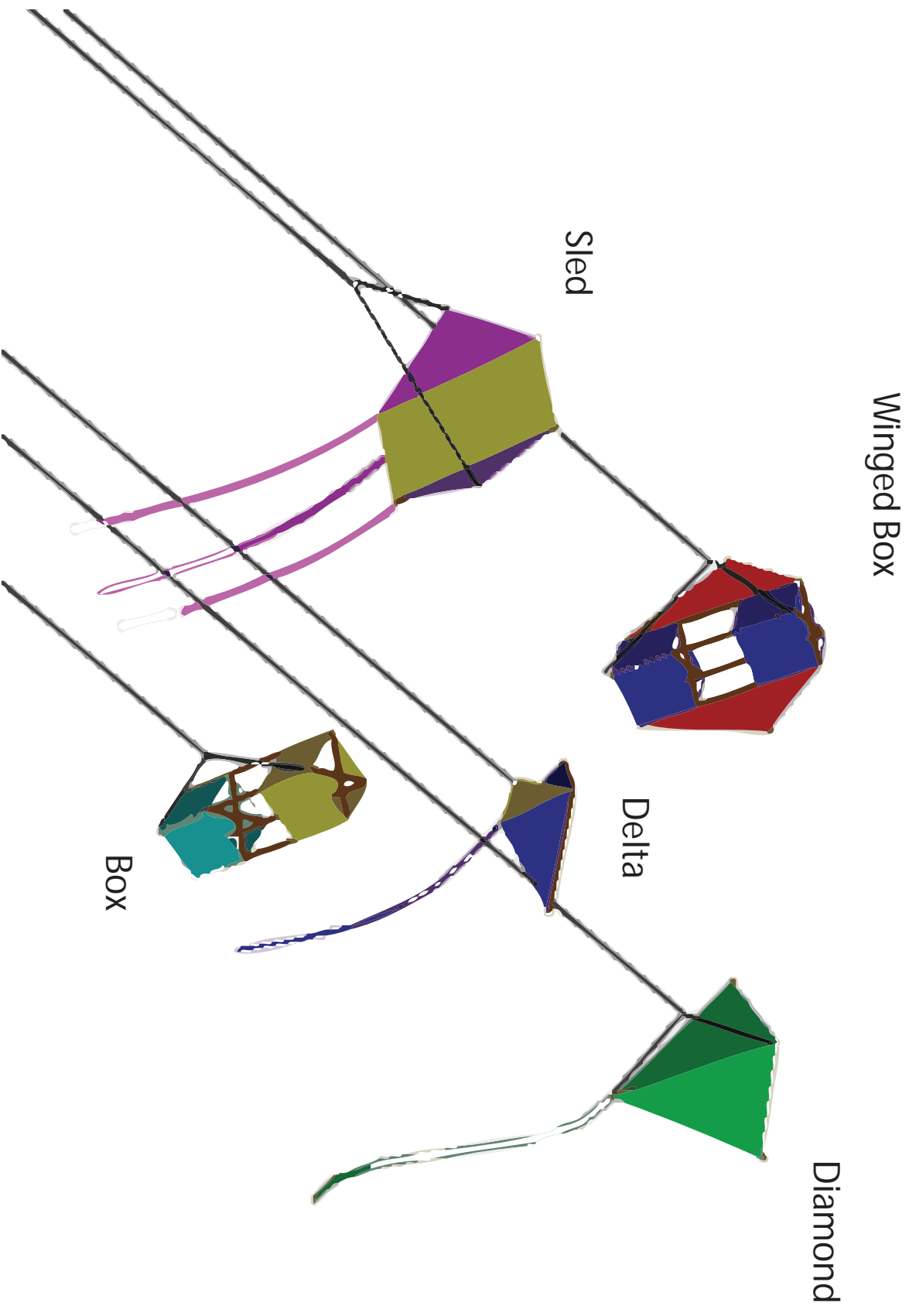

(Photo courtesy of NASA)

Img. 10 Benjamin Franklin flying his kite



(Public Domain)

Img. 11 Leonardo da Vinci's Ornithopter



Img. 12 Wright yer



(Public Domain)

Img. 13 Rogallo's wing

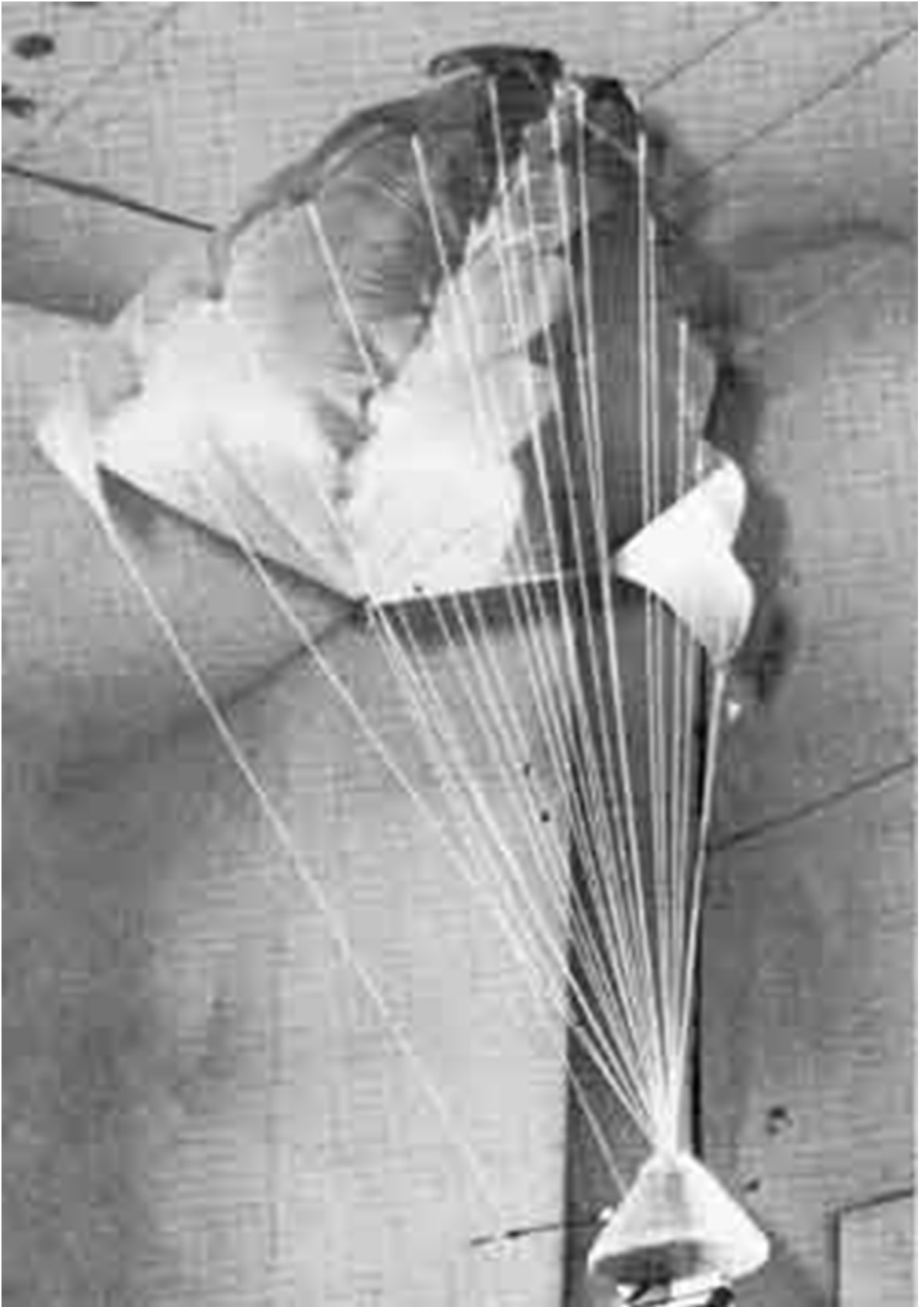

(Public Domain)

March 20, 1951

G. S. ROGALLO ET AL
FLEXIBLE KITE

2,546,078

Filed Nov. 23, 1948

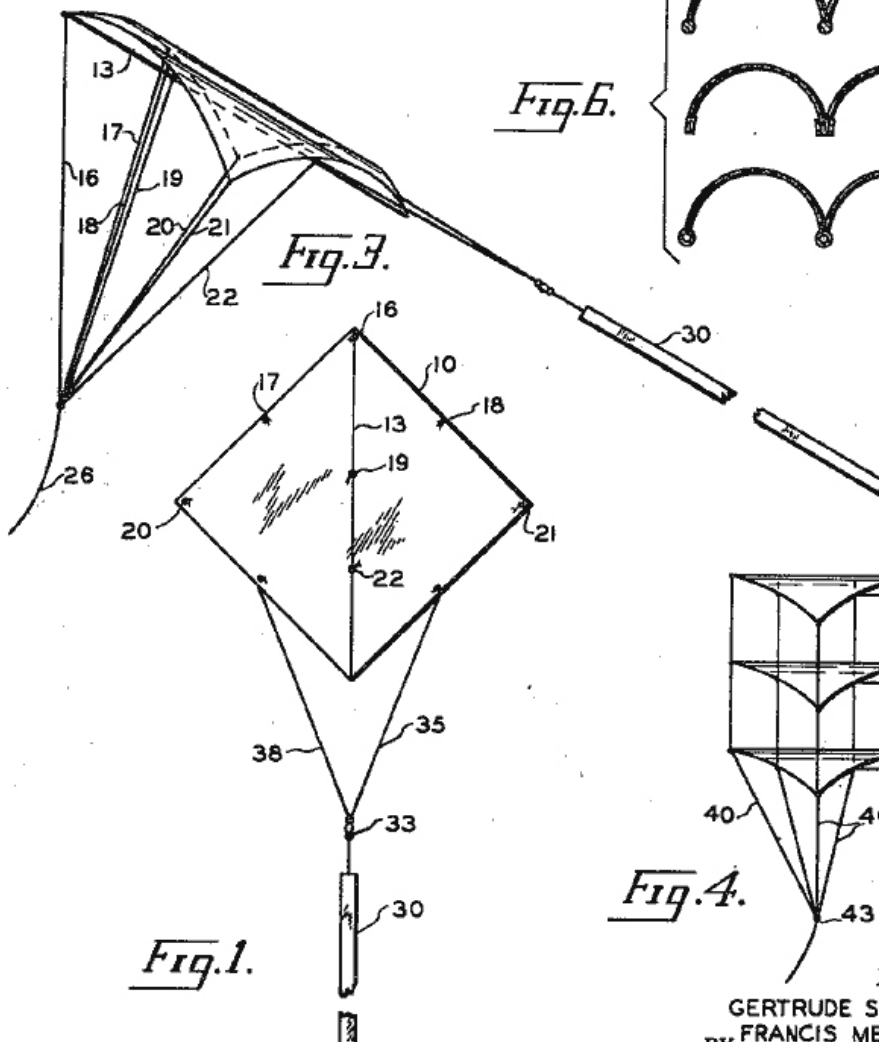
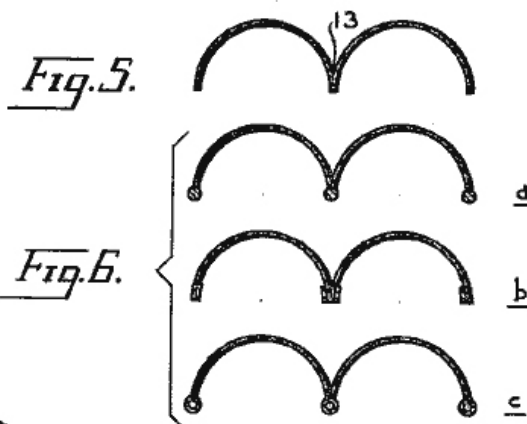
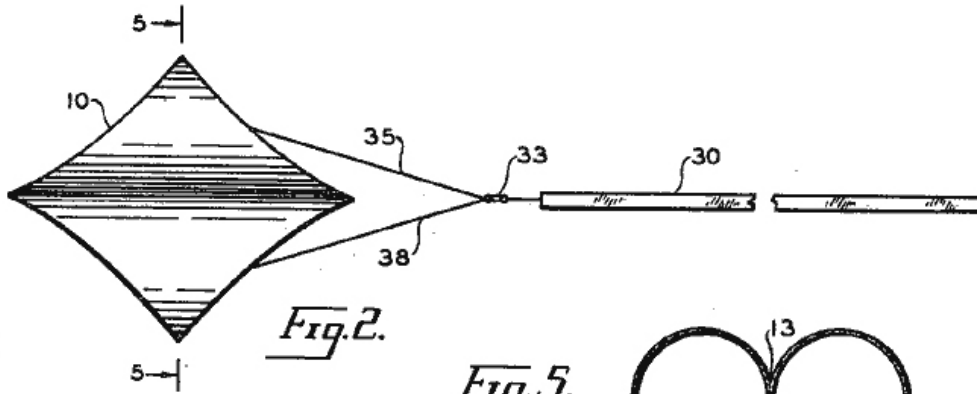

INVENTORS.
GERTRUDE SUGDEN ROGALLO
FRANCIS MELVIN ROGALLO

(Public Domain)

Img. 15 Forces on a kite

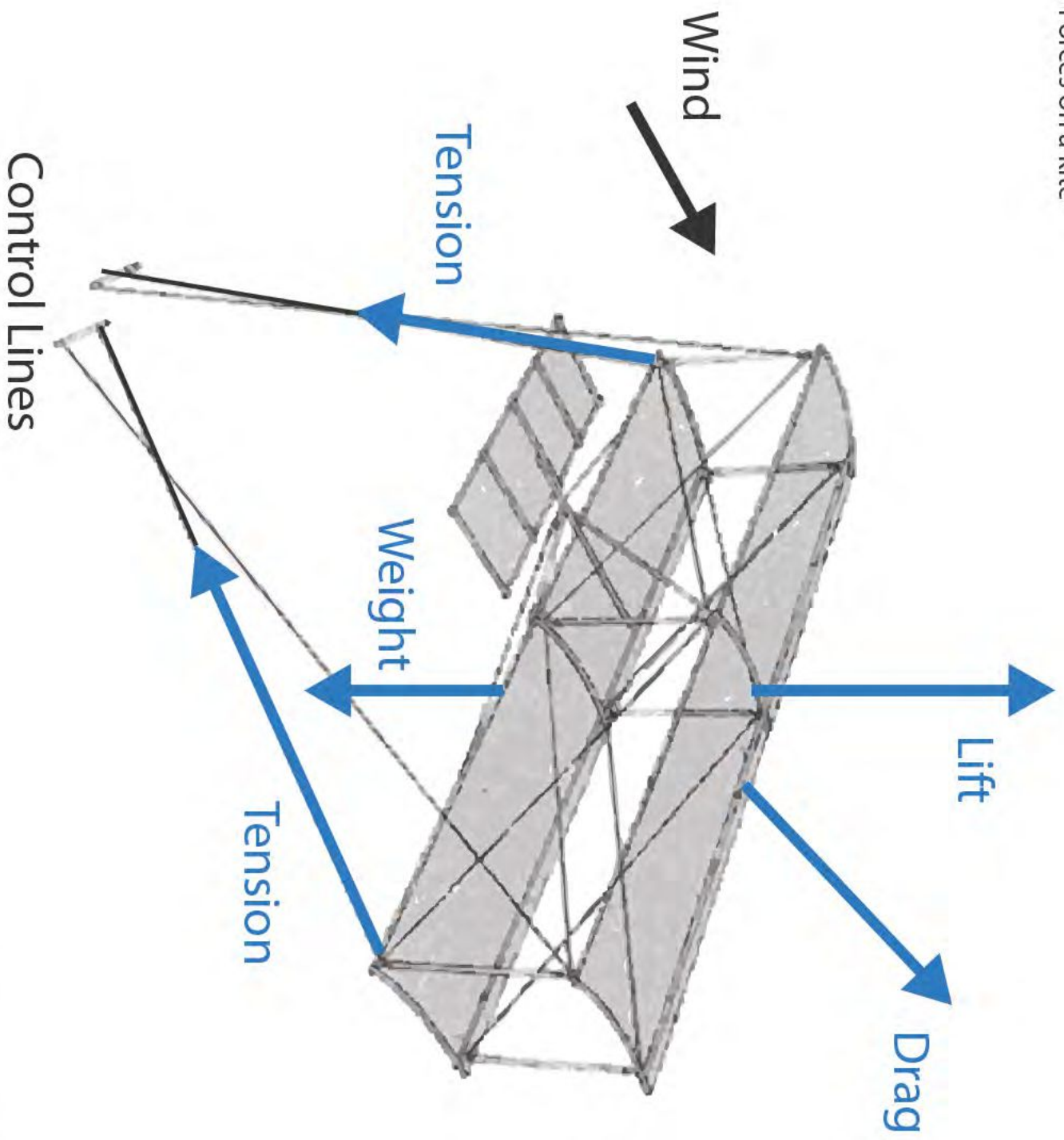

(Photo courtesy of NASA)

Aeronautics
Research
Mission
Directorate

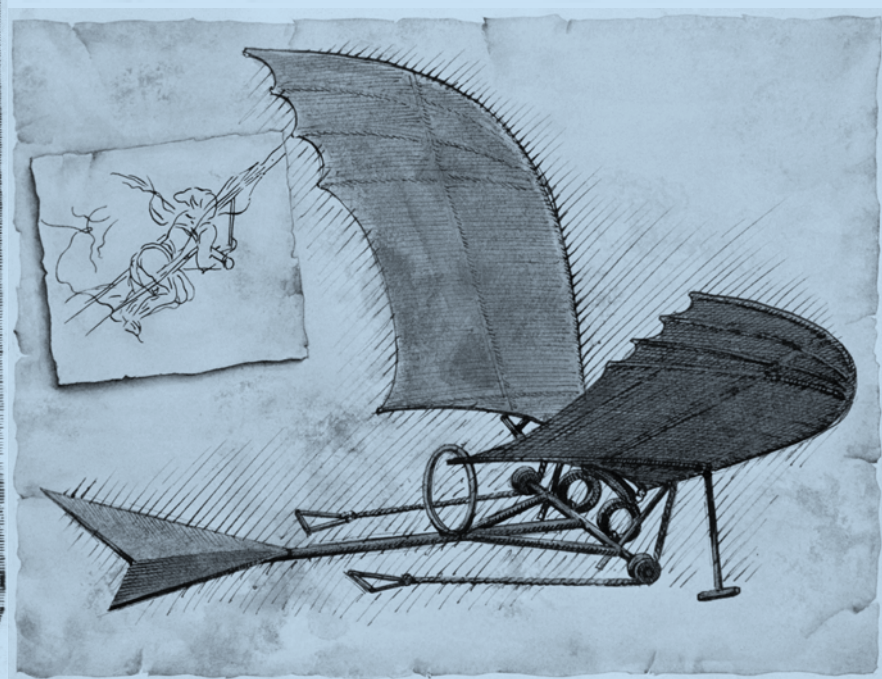
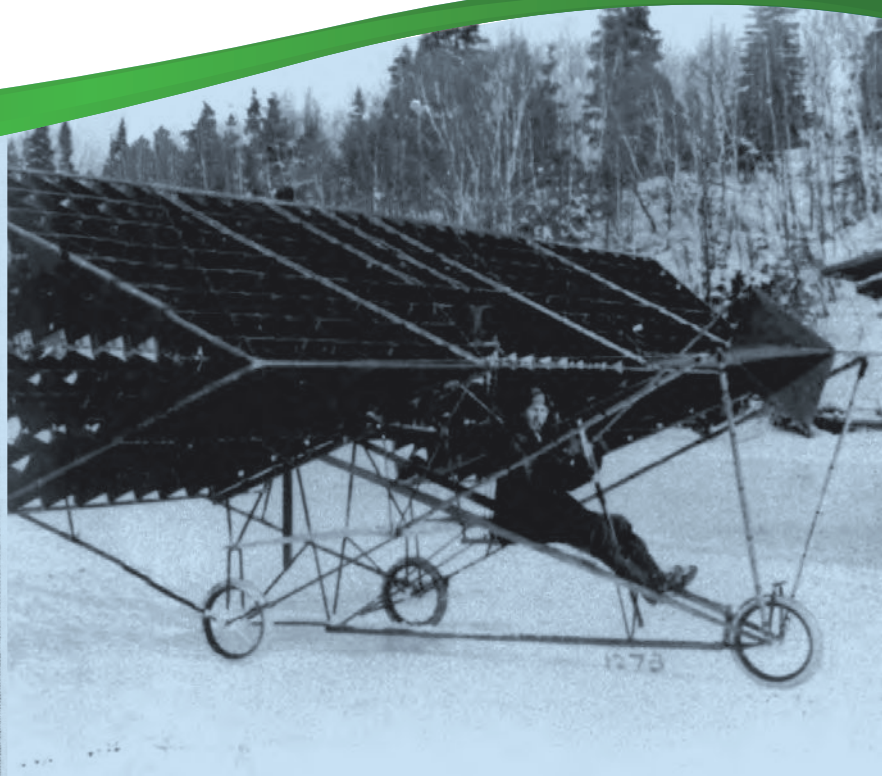

principles of flight