

[www.kidsactivitydownloads.com](http://www.kidsactivitydownloads.com)



**Kids Activity Downloads**

[Black eyed Susan coloring sheet.pdf](#)  
[Butterfly coloring sheet.pdf](#)  
[Francolin coloring sheet.pdf](#)  
[Gecko coloring sheet.pdf](#)  
[Lioness coloring sheet.pdf](#)  
[Malelion coloring sheet.pdf](#)  
[Monarch coloring sheet.pdf](#)  
[Pelican coloring sheet.pdf](#)  
[Red fox coloring sheet.pdf](#)  
[Rhino coloring sheet.pdf](#)  
[Squirrel coloring sheet.pdf](#)  
[Stork coloring sheet.pdf](#)  
[Toad coloring sheet.pdf](#)  
[Toucan coloring sheet.pdf](#)  
[Turtle coloring sheet.pdf](#)  
[American Bullfrog coloring sheet.pdf](#)  
[Banded Water Snake coloring sheet.pdf](#)  
[California Newt coloring sheet.pdf](#)  
[Red-Eared Slider coloring sheet.pdf](#)  
[Sierra Madre Yellow-Legged Frog coloring sheet.pdf](#)  
[Western Pond Turtle coloring sheet.pdf](#)  
[Bat - connect the dots coloring sheet.pdf](#)  
[Bee - connect the dots coloring sheet.pdf](#)  
[Butterfly - connect the dots coloring sheet.pdf](#)  
[Eagle - connect the dots coloring sheet.pdf](#)  
[Frog - connect the dots coloring sheet.pdf](#)  
[Hummingbird - connect the dots coloring sheet.pdf](#)  
[Kudzu - connect the dots coloring sheet.pdf](#)  
[Mosquito - connect the dots coloring sheet.pdf](#)  
[Moth - connect the dots coloring sheet.pdf](#)  
[Nutria - connect the dots coloring sheet.pdf](#)  
[Pronghorn - connect the dots coloring sheet.pdf](#)  
[Stilt - connect the dots coloring sheet.pdf](#)

[Ant maze.pdf](#)

[Bee maze.pdf](#)

[Children Bluebird Activity Book.pdf](#)

[Mealworm Ranch - An experiment in scientific observation.pdf](#)

[Save Animal Tracks as Plaster Casts Activity Book.pdf](#)

[Turtle maze.pdf](#)

# Black-eyed Susan



 USGS Coloring Series

# Rice Paper Butterfly

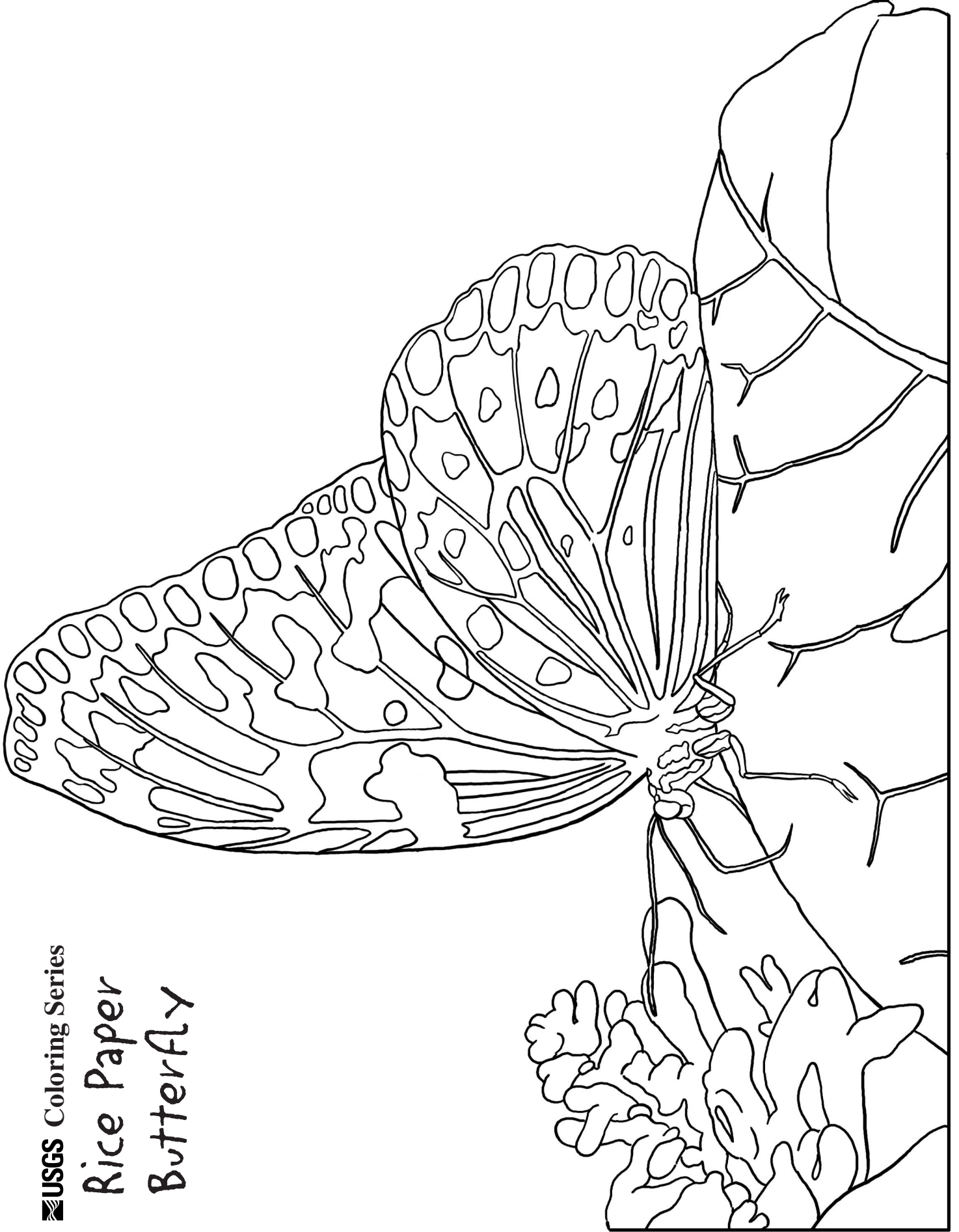

 USGS Coloring Series

# Gray francolin



# Gecko

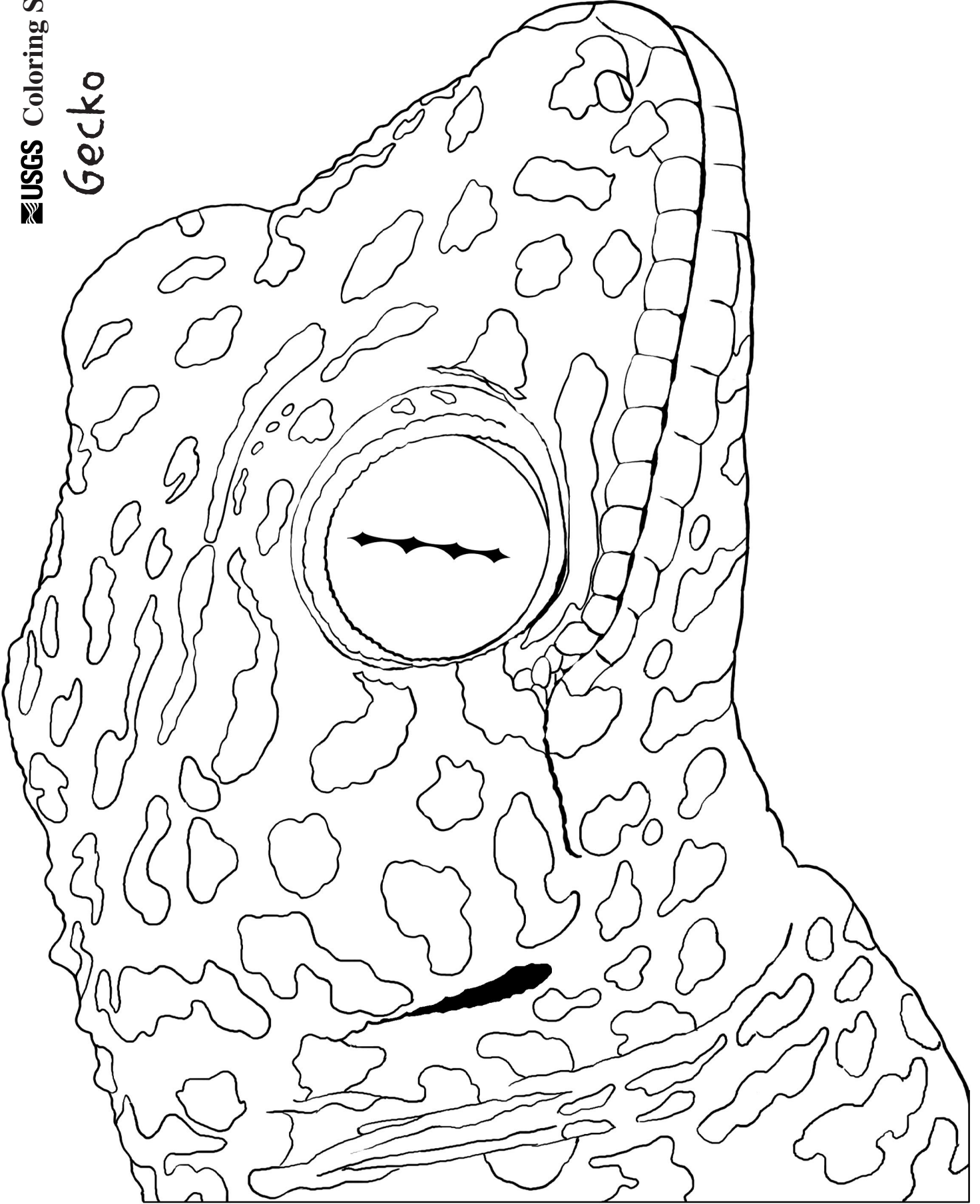

# Lioness





 **USGS**  
Coloring Series

**Male Lion**

# Monarch Butterfly

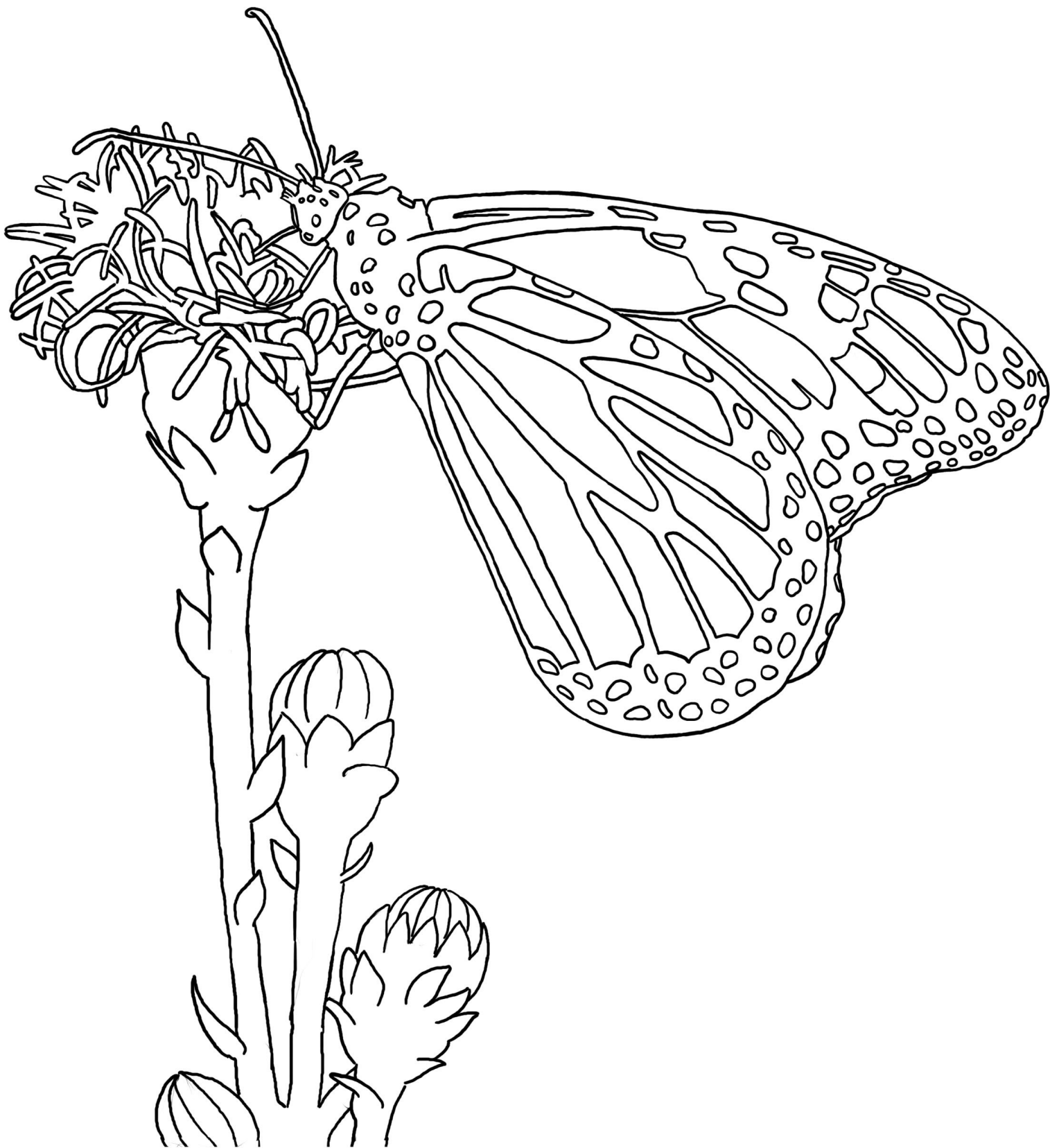

# Brown Pelican

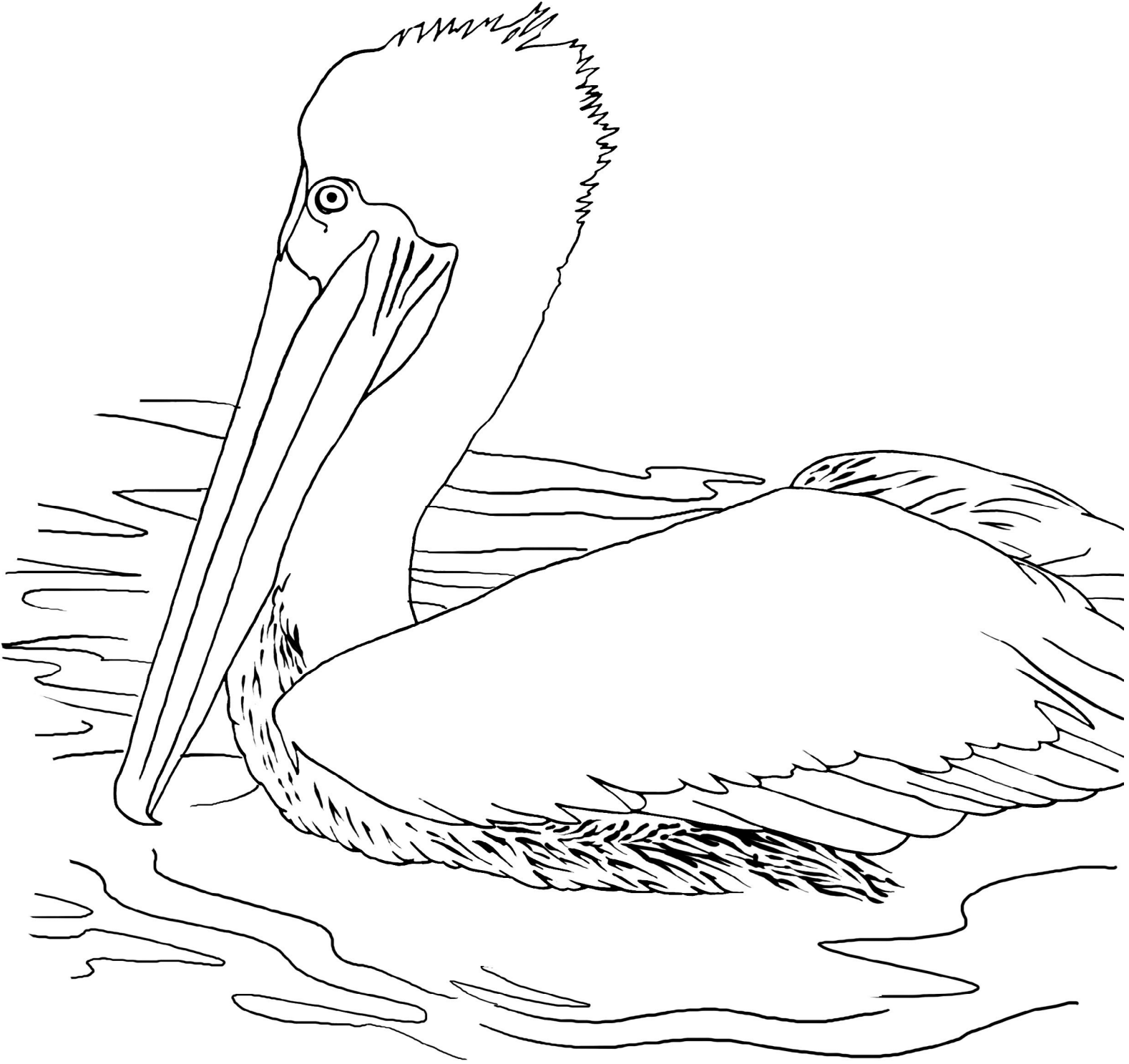

# Red Fox



 USGS Coloring Series

# White Rhino



# Squirrel



# Maguari Stork



# American Toad



# Toucan

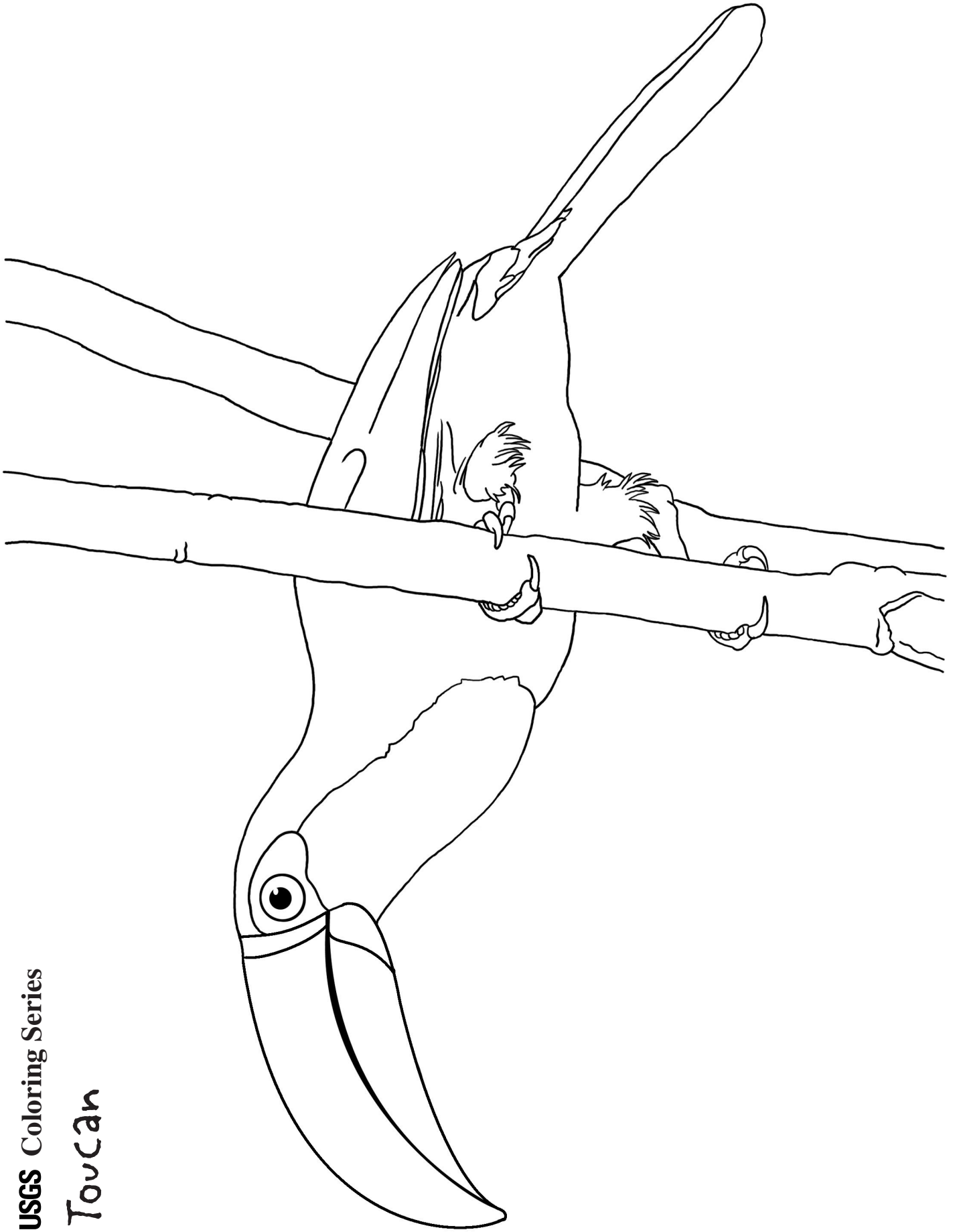

 USGS Coloring Series

# Wood Turtle

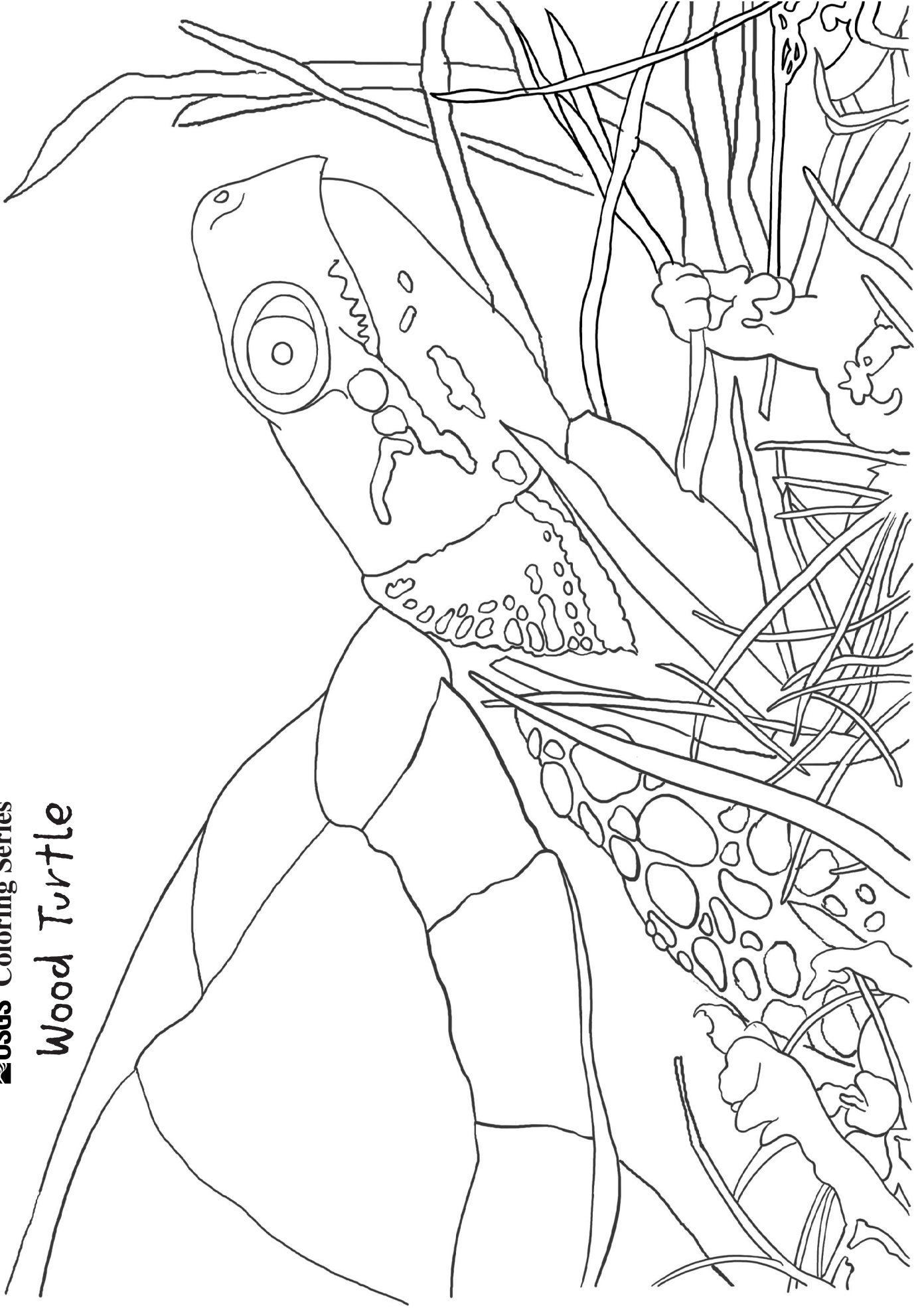

## AMERICAN BULLFROG

*(Rana catesbeiana)*

**These voracious predators were introduced from the Eastern U.S.,  
and now they are eating California's native frog species.**

*Image Credit: Ben Young Landis/Chris Brown  
U.S. Geological Survey-Western Ecological Research Center*



## Banded Water Snake

*(Nerodia fasciata)*

Imported from the Eastern and Central U.S. as pets, these nonvenomous snakes now prey on California's native fish and amphibians. When handled by humans, they often defecate and emit foul-smelling musk.

*Image Credit: Ben Young Landis/Chris Brown  
U.S. Geological Survey-Western Ecological Research Center*

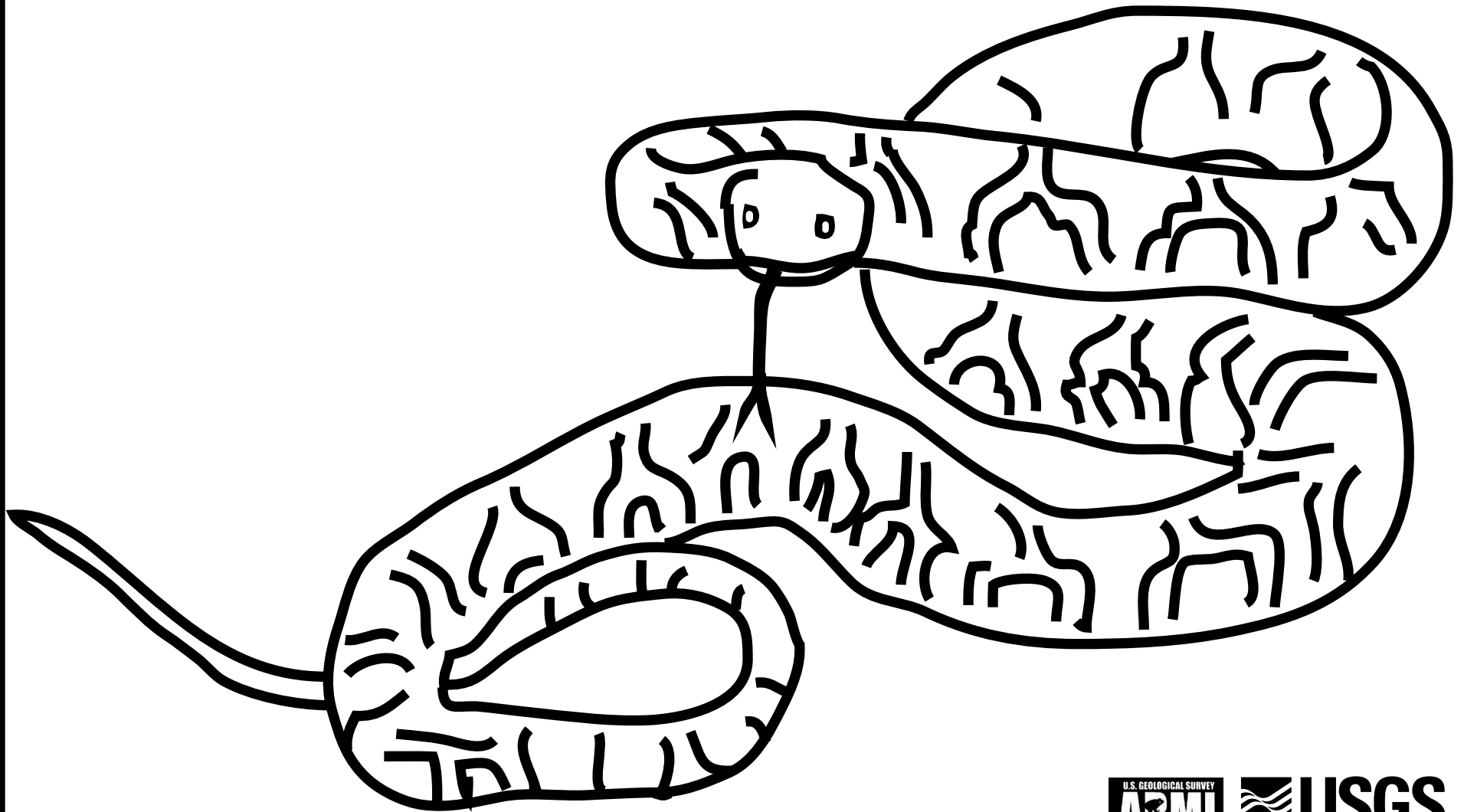

## CALIFORNIA NEWT

*(Taricha torosa)*

**This orange and brown California native is under threat from invasive species that eat its eggs, such as crayfish released from bait shops and classrooms and mosquitofish released for pest control.**

*Image Credit: Ben Young Landis/Chris Brown  
U.S. Geological Survey-Western Ecological Research Center*

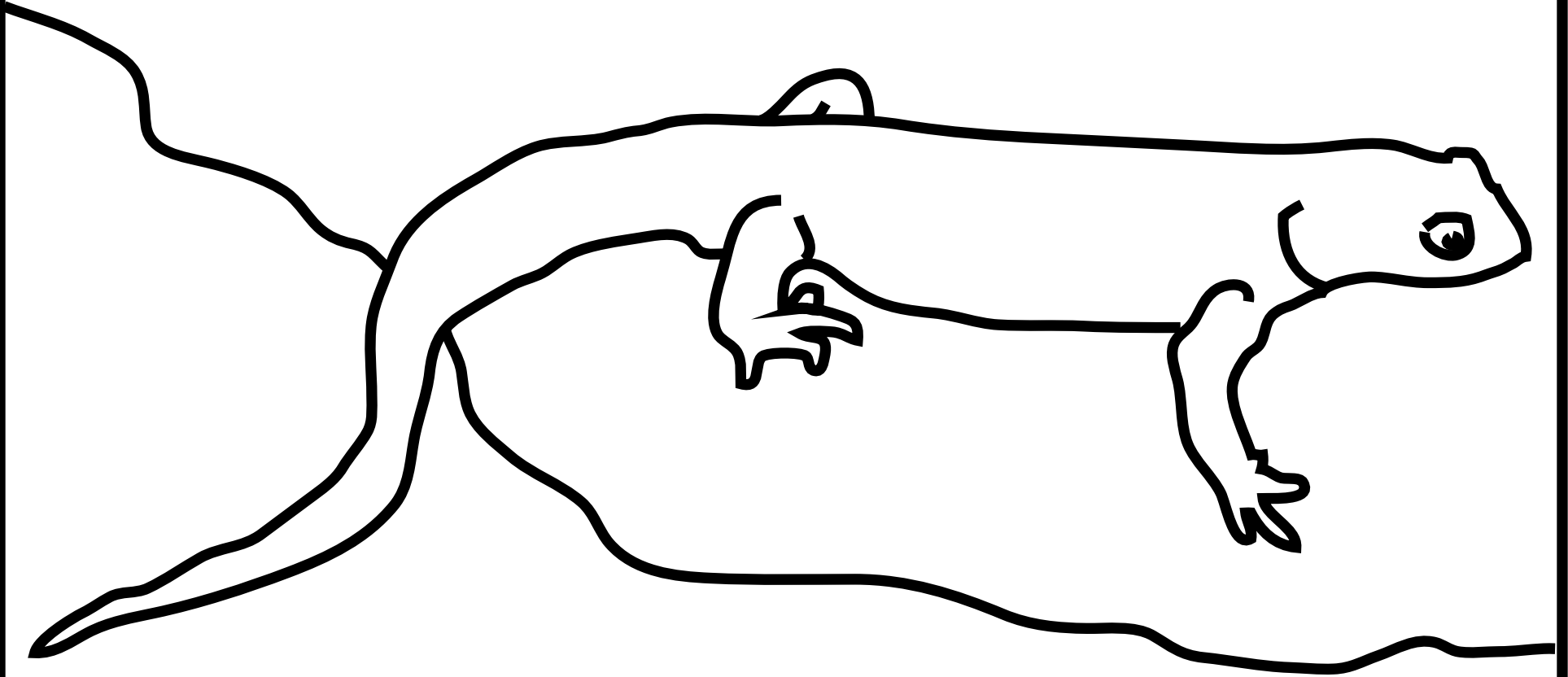

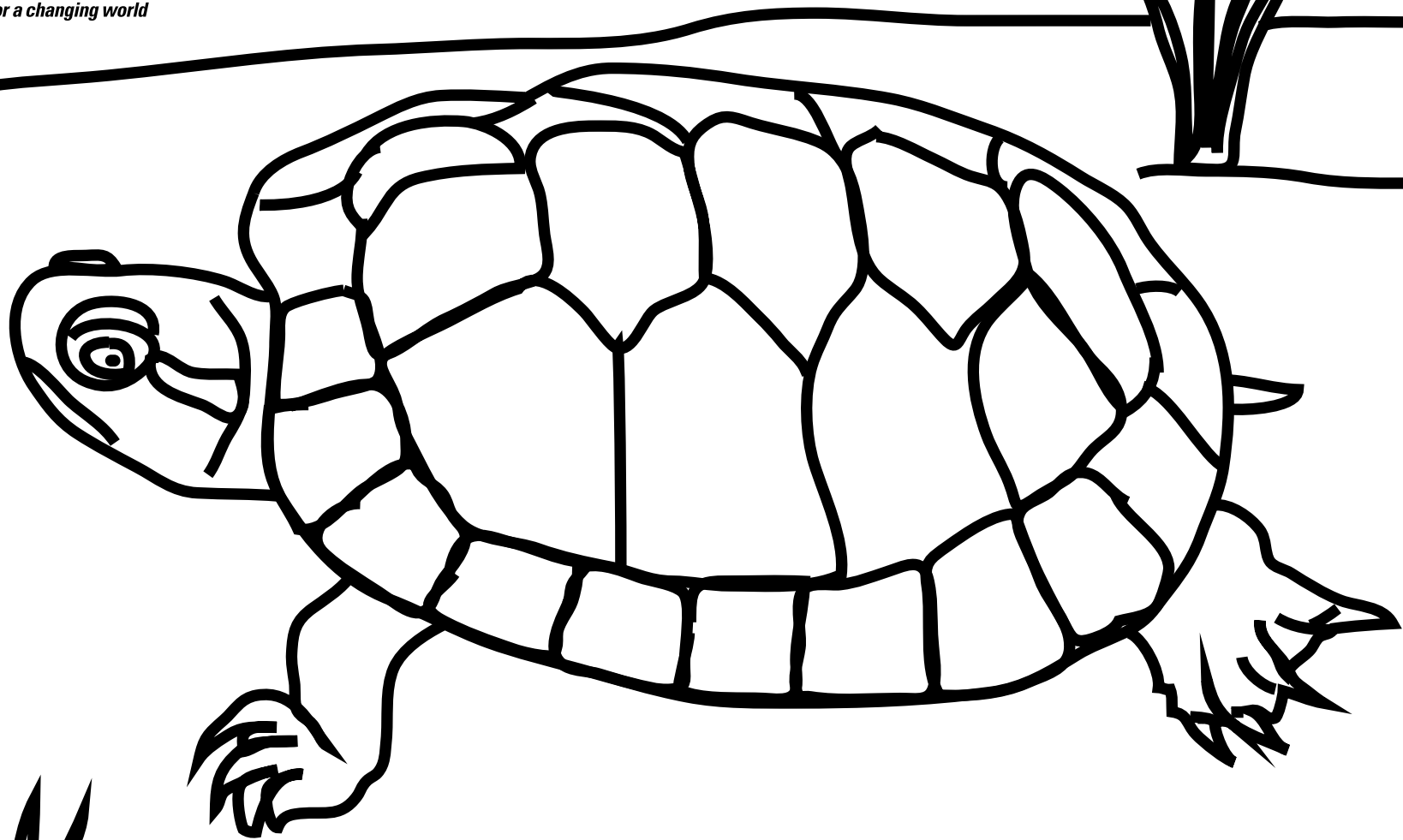

**RED-EARED SLIDER**  
*(Trachemys scripta elegans)*

**People sometimes release this popular pet turtle into the wild,  
but this species can bully California's native pond turtles for food and shelter.**

*Image Credit: Ben Young Landis/Chris Brown  
U.S. Geological Survey-Western Ecological Research Center*

# MOUNTAIN YELLOW-LEGGED FROG

(*Rana muscosa*)

Also known as the Sierra Madre yellow-legged frog,  
government and zoo scientists are studying this endangered species.

*Image Credit: Ben Young Landis/Adam Backlin  
U.S. Geological Survey-Western Ecological Research Center*

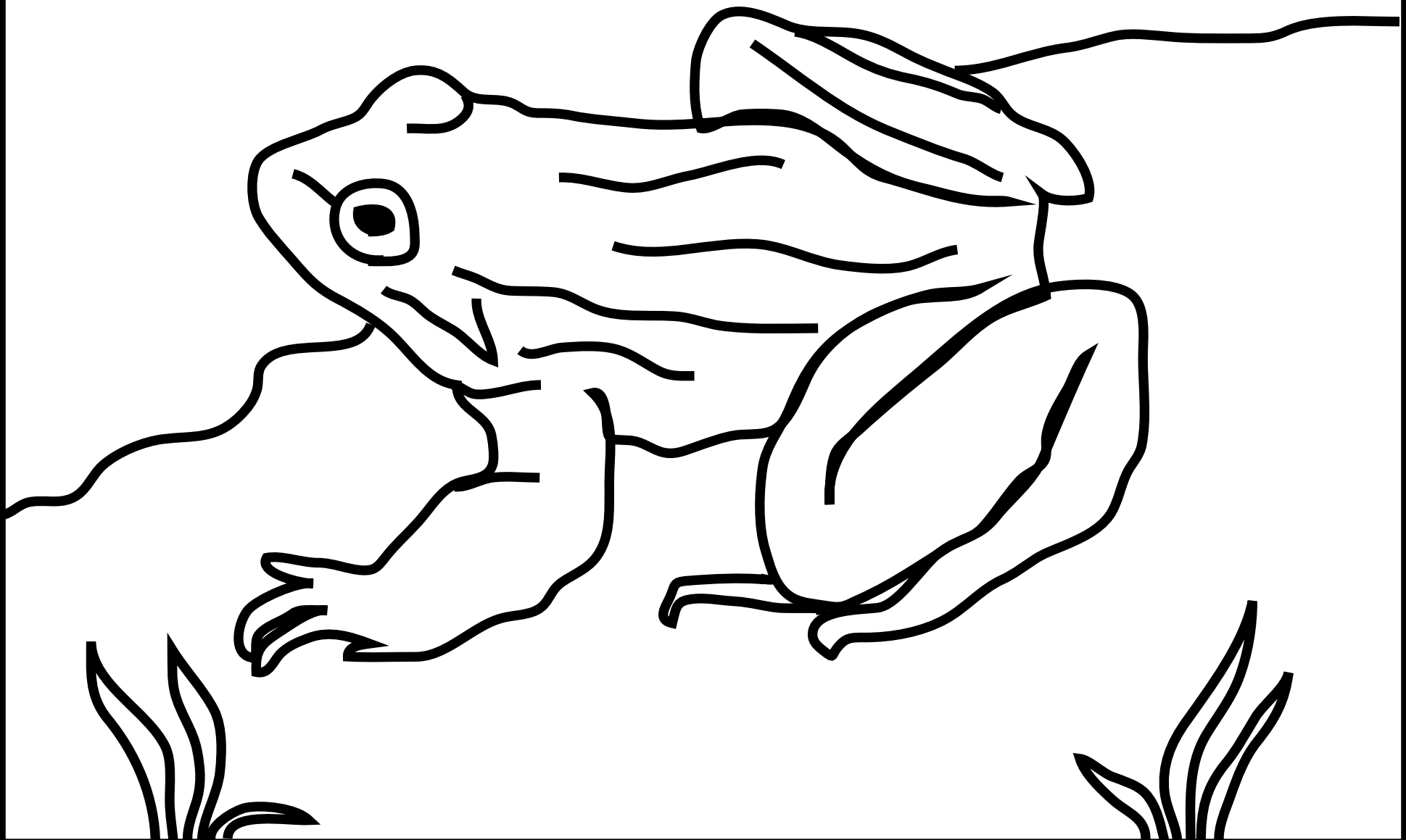

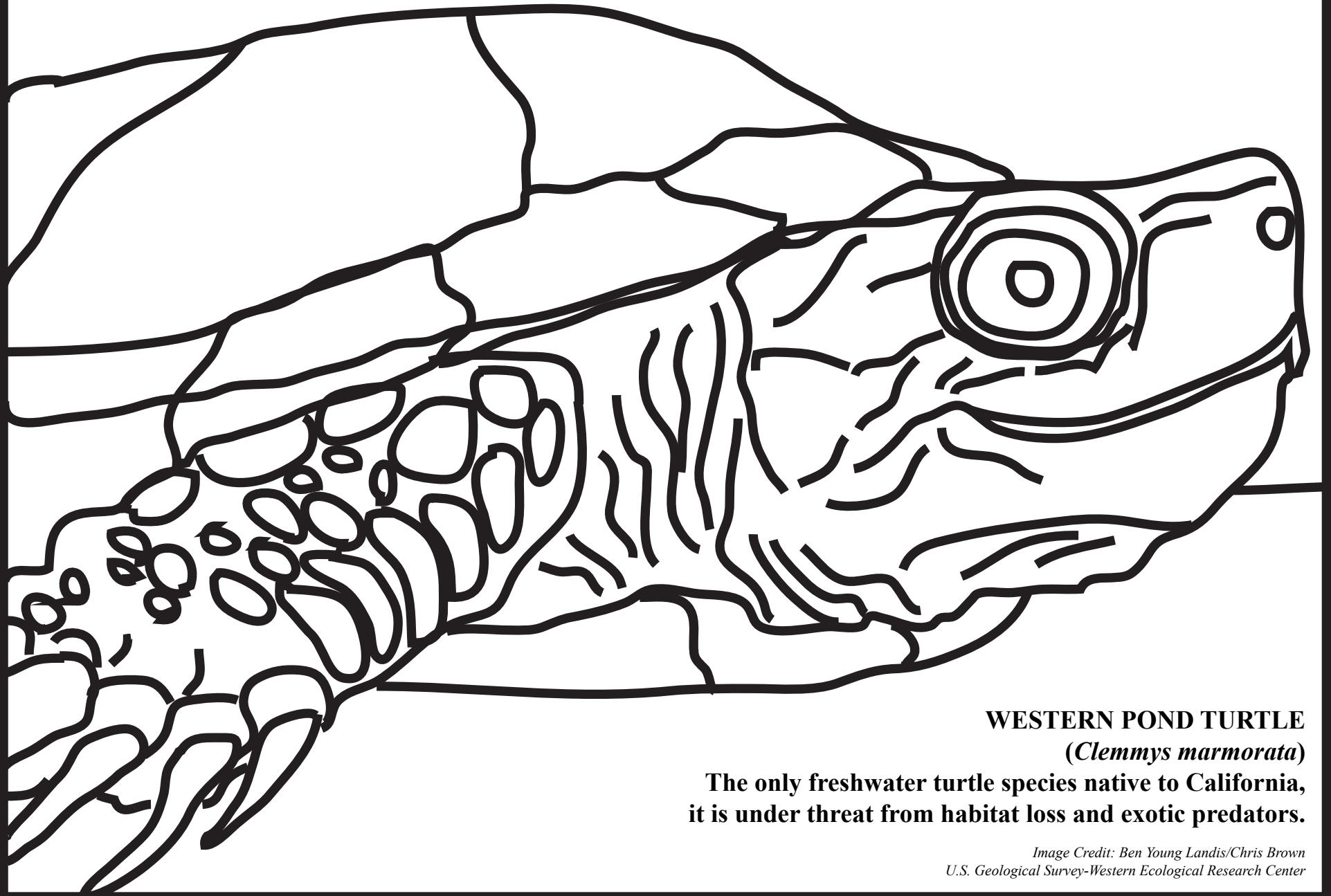

**WESTERN POND TURTLE**  
*(Clemmys marmorata)*

**The only freshwater turtle species native to California,  
it is under threat from habitat loss and exotic predators.**

*Image Credit: Ben Young Landis/Chris Brown  
U.S. Geological Survey-Western Ecological Research Center*

Connect the Dots to Discover the  
**Pollinator**

Thanks to the wonderful work of *bats* (shown below) and other animal pollinators, the world's flowering plants are able to reproduce and bear fruit, providing many of the foods we eat, the plant materials we and other organisms use, and the beauty we see around us.

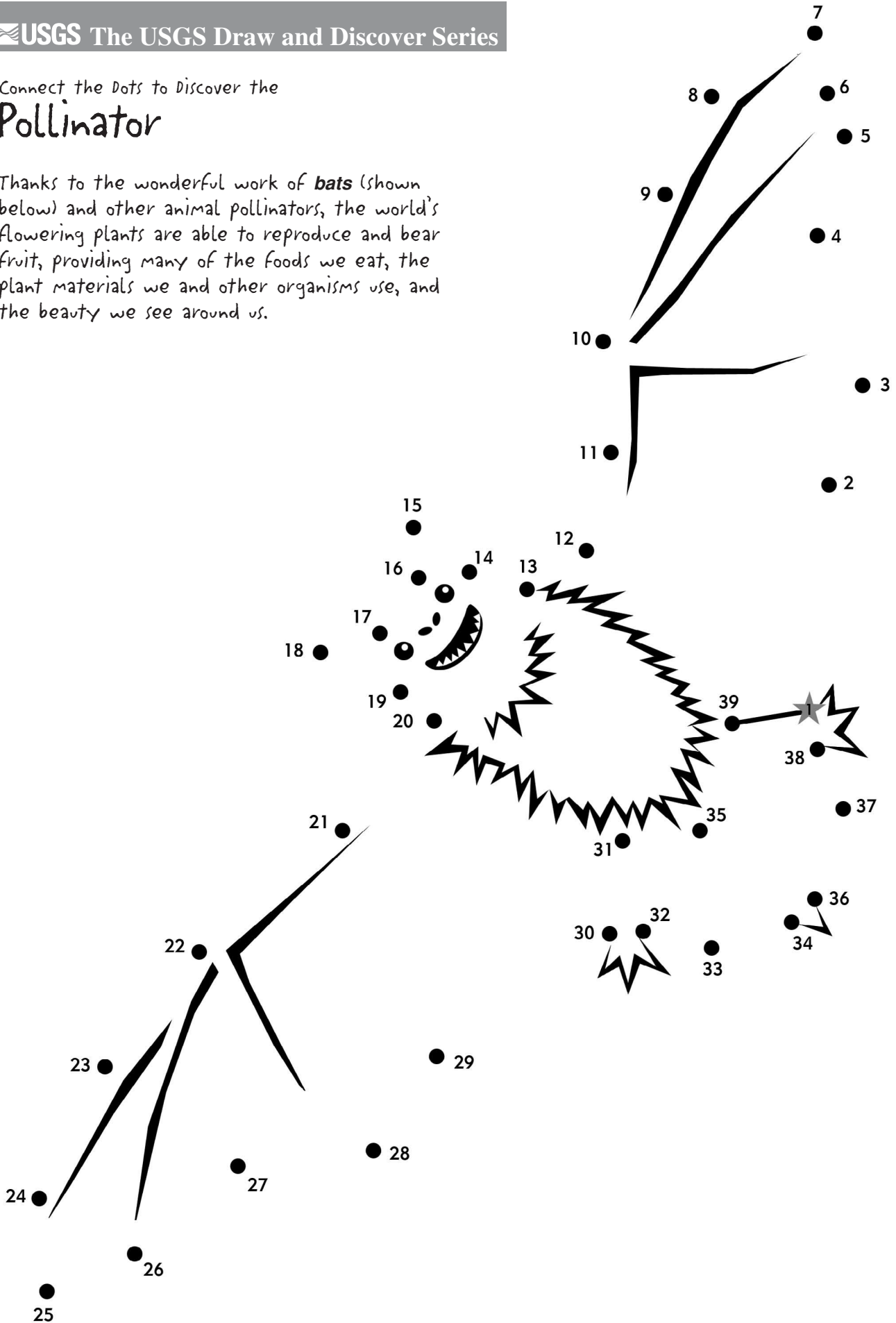

Connect the Dots to Discover the  
**Pollinator**

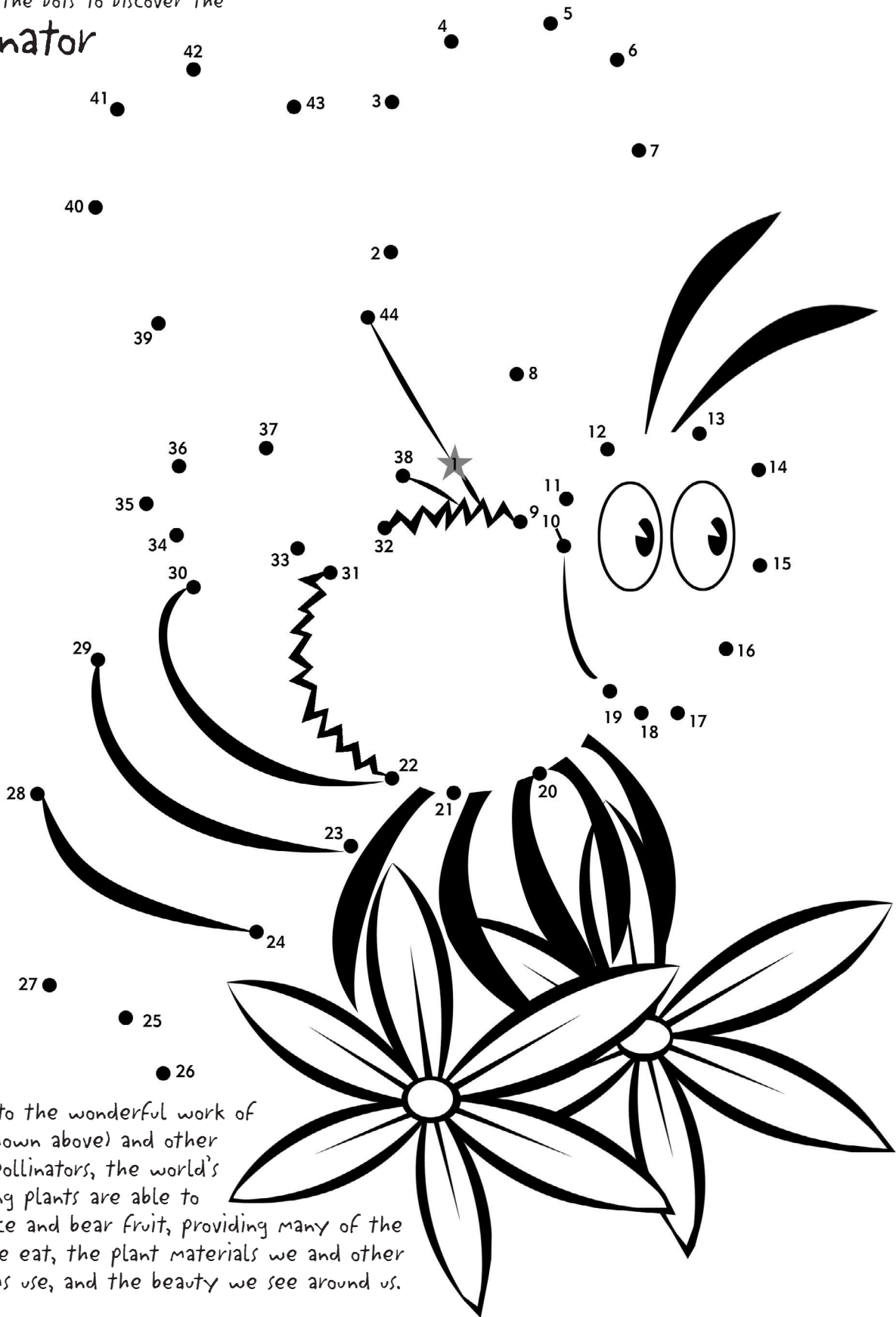

Thanks to the wonderful work of **bees** (shown above) and other animal pollinators, the world's flowering plants are able to reproduce and bear fruit, providing many of the foods we eat, the plant materials we and other organisms use, and the beauty we see around us.

Connect the Dots to Discover the  
**Pollinator**

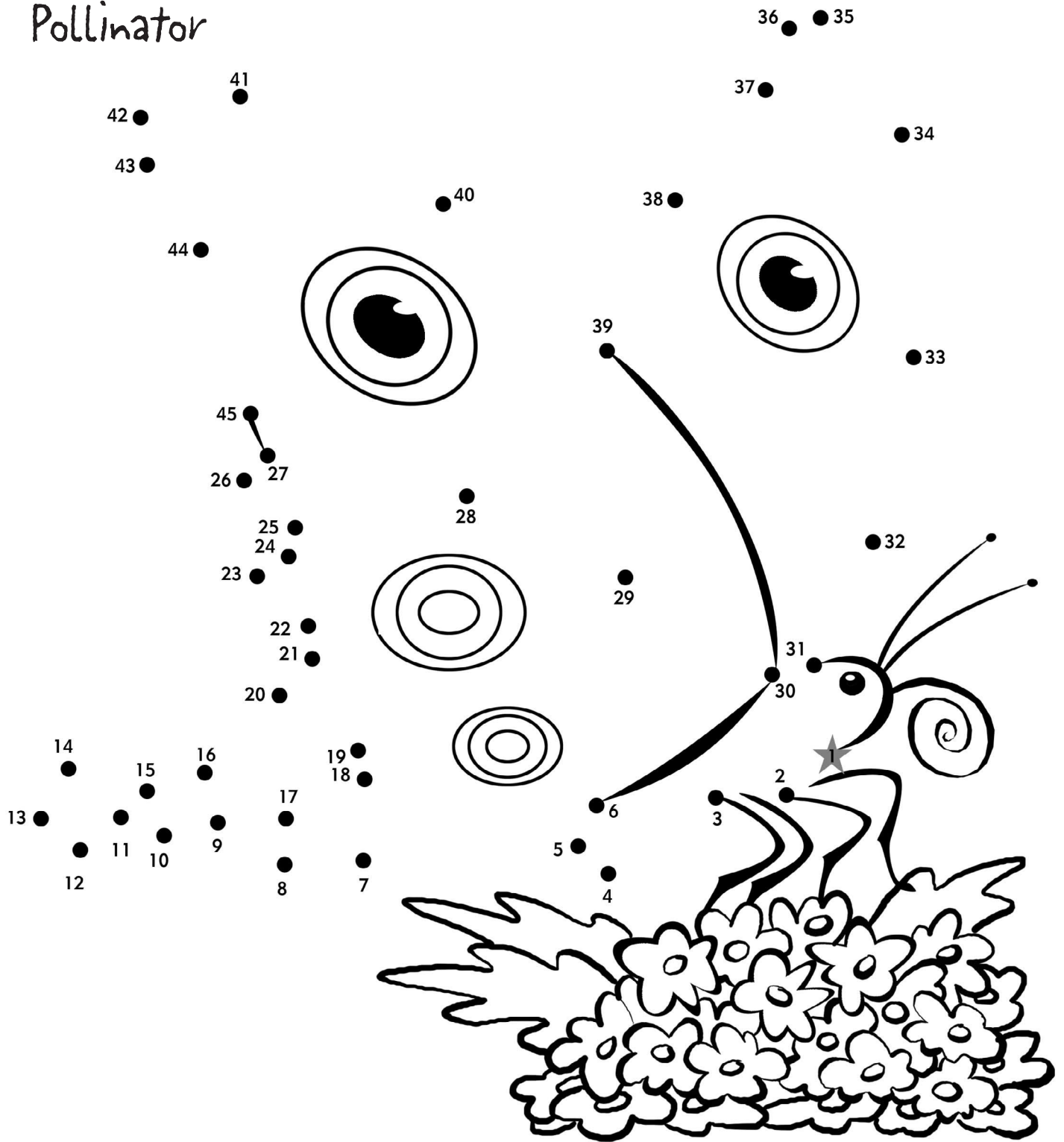

Thanks to the wonderful work of **butterflies** (shown above) and other animal pollinators, the world's flowering plants are able to reproduce and bear fruit, providing many of the foods we eat, the plant materials we and other organisms use, and the beauty we see around us.

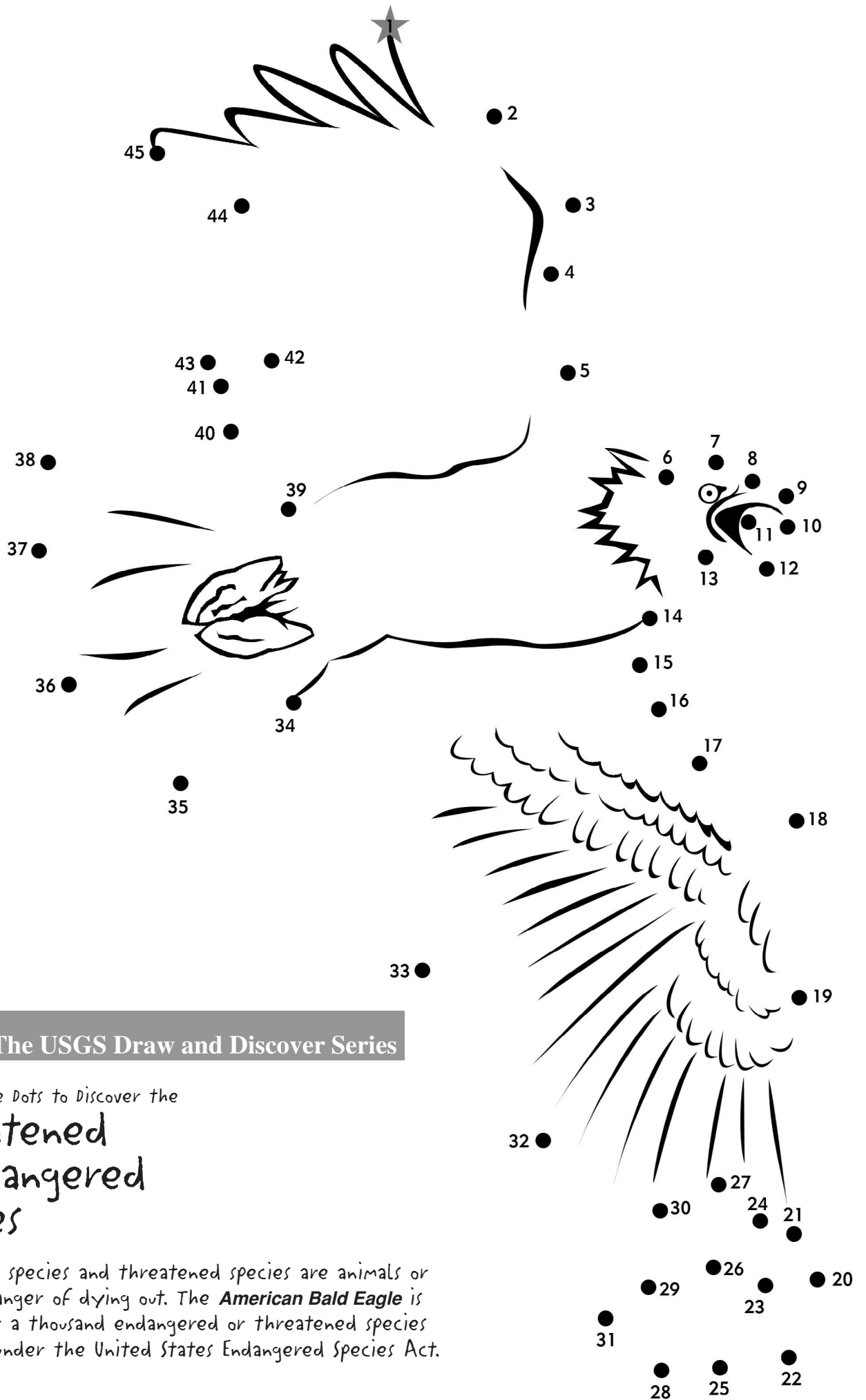

 **USGS** The USGS Draw and Discover Series

Connect the Dots to Discover the  
**Threatened  
 & Endangered  
 Species**

Endangered species and threatened species are animals or plants in danger of dying out. The **American Bald Eagle** is one of over a thousand endangered or threatened species protected under the United States Endangered Species Act.

Connect the Dots to Discover the  
**Threatened  
& Endangered  
Species**

Endangered species and threatened species are animals or plants in danger of dying out. The **California Red-Legged Frog** is one of over a thousand endangered or threatened species protected under the United States Endangered Species Act.

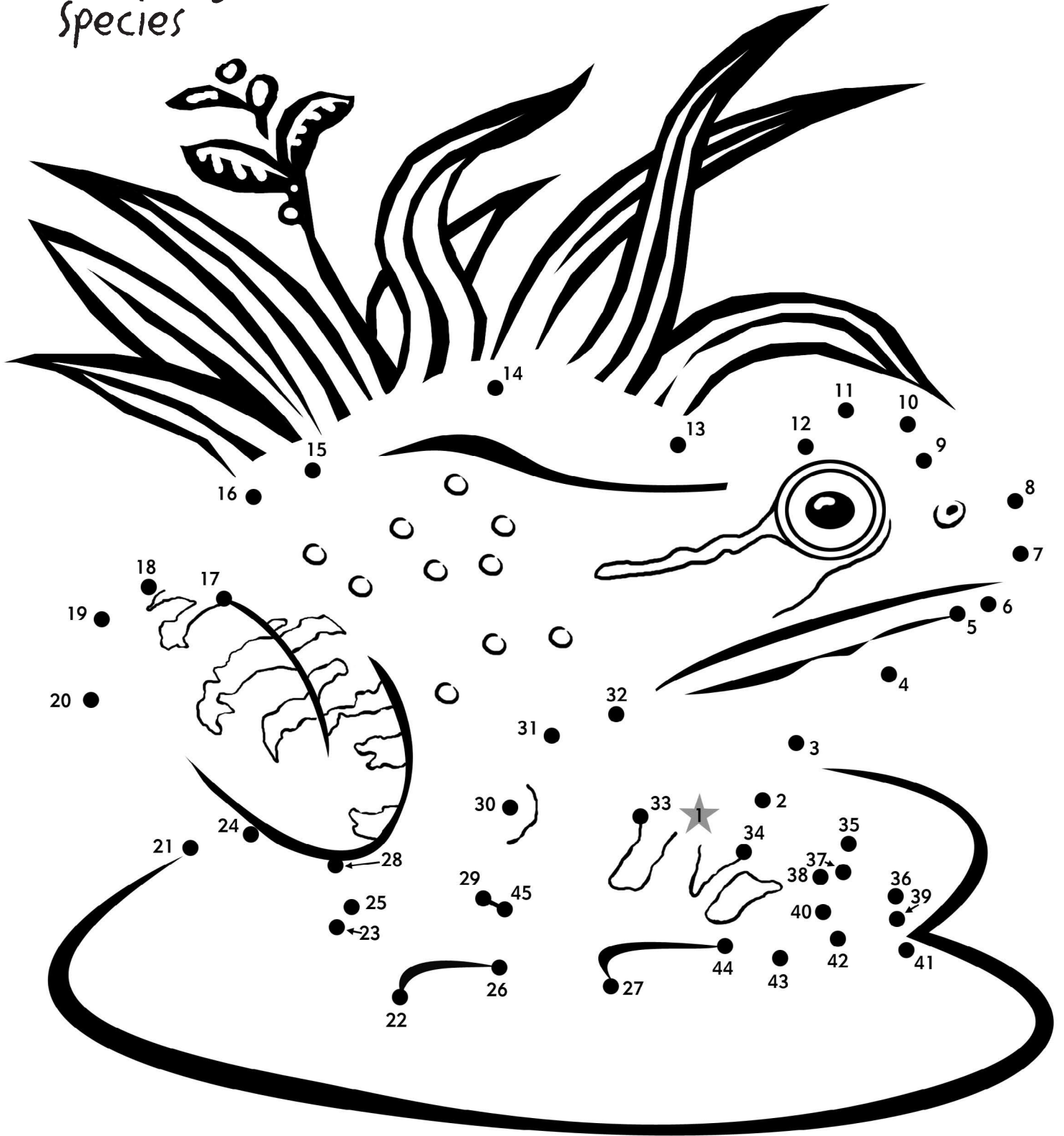

Connect the Dots to Discover the  
Pollinator

Thanks to the wonderful work of *hummingbirds* and other animal pollinators, the world's flowering plants are able to reproduce and bear fruit, providing many of the foods we eat, the plant materials we and other organisms use, and the beauty we see around us.

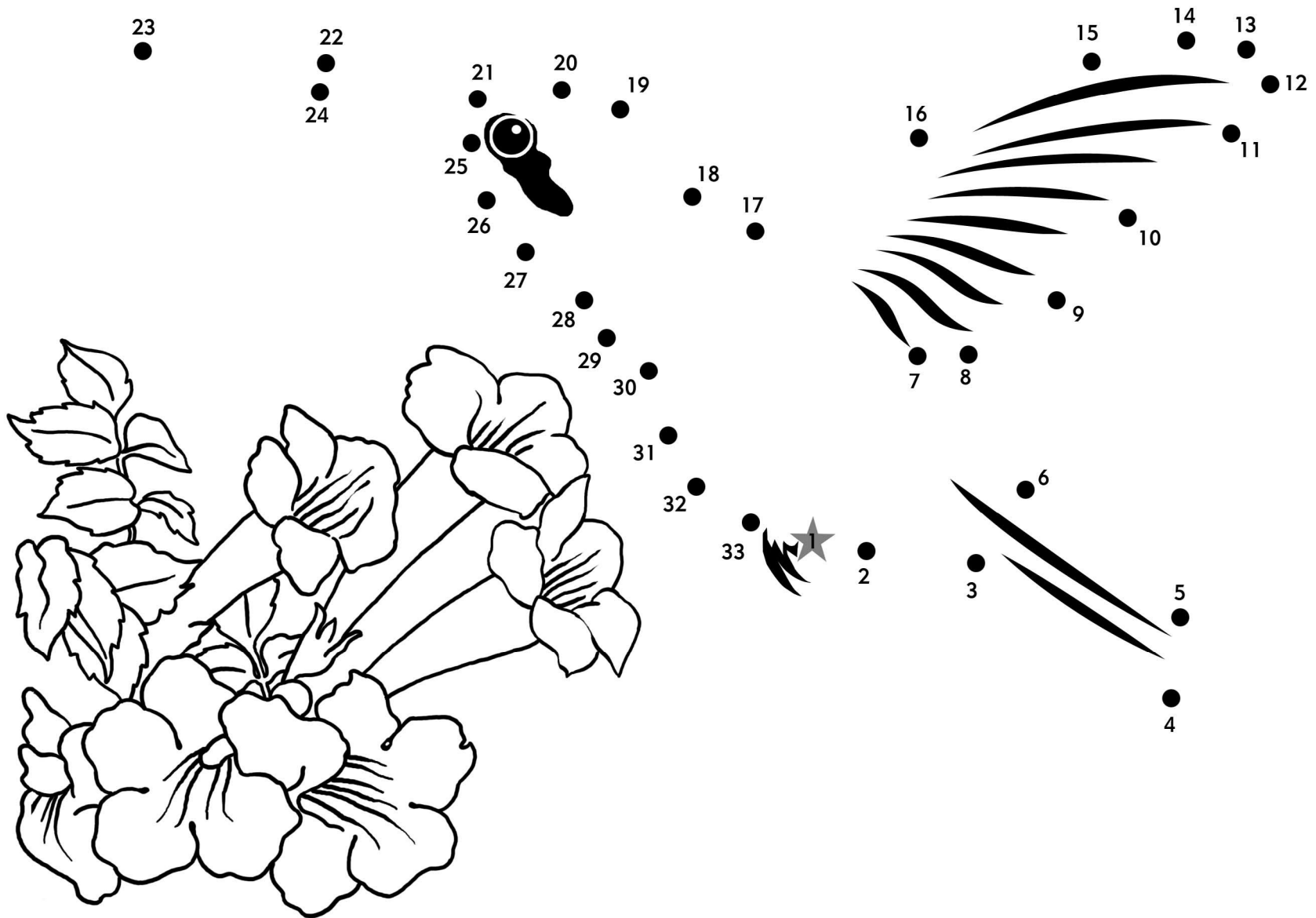

Connect the Dots to Discover the  
**Invasive Species**

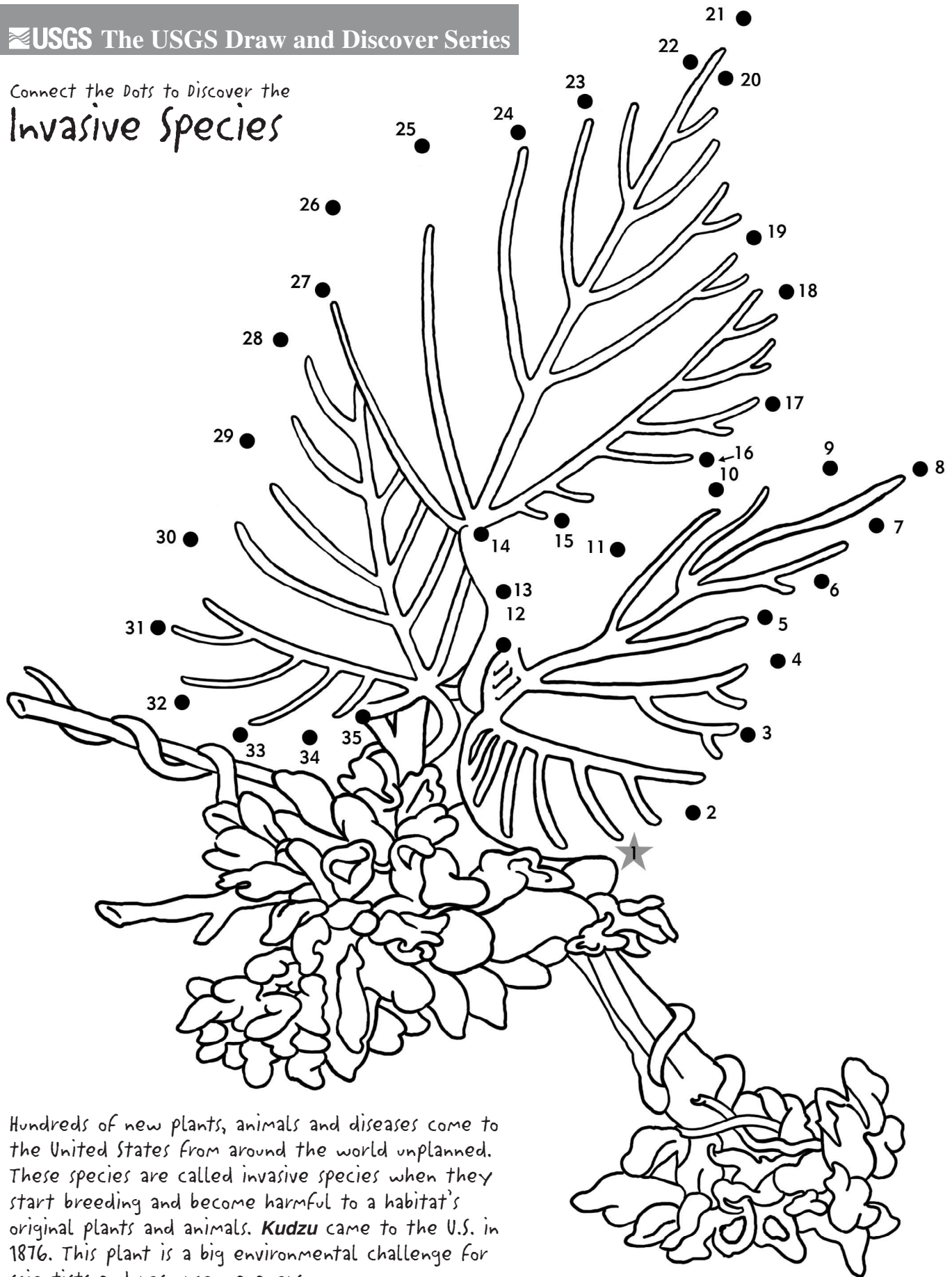

Hundreds of new plants, animals and diseases come to the United States from around the world unplanned. These species are called invasive species when they start breeding and become harmful to a habitat's original plants and animals. **Kudzu** came to the U.S. in 1876. This plant is a big environmental challenge for scientists and resource managers.

Connect the Dots to Discover the  
**Invasive Species**

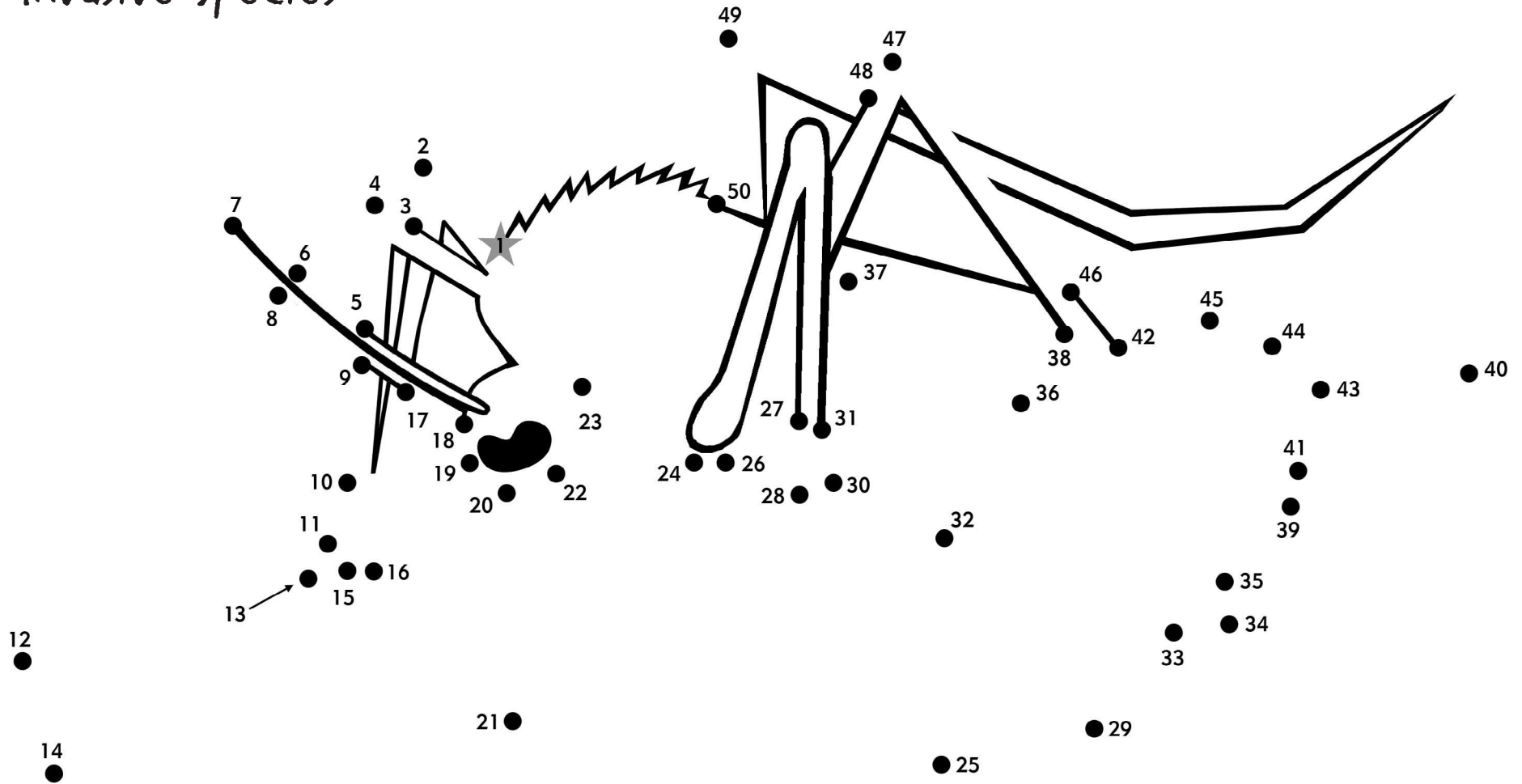

Hundreds of new plants, animals and diseases come to the United States from around the world unplanned. These species are called invasive species when they start breeding and become harmful to a habitat's original plants and animals. The **Asian Tiger Mosquito**, which can carry the West Nile Virus, came to the U.S. in 1985 (there have always been mosquitos in the US, it's just this particular type is new). This insect is a big environmental challenge for scientists and resource managers.

# Connect the Dots to Discover the Pollinator

Thanks to the wonderful work of *moths* and other animal pollinators, the world's flowering plants are able to reproduce and bear fruit, providing many of the foods we eat, the plant materials we and other organisms use, and the beauty we see around us.

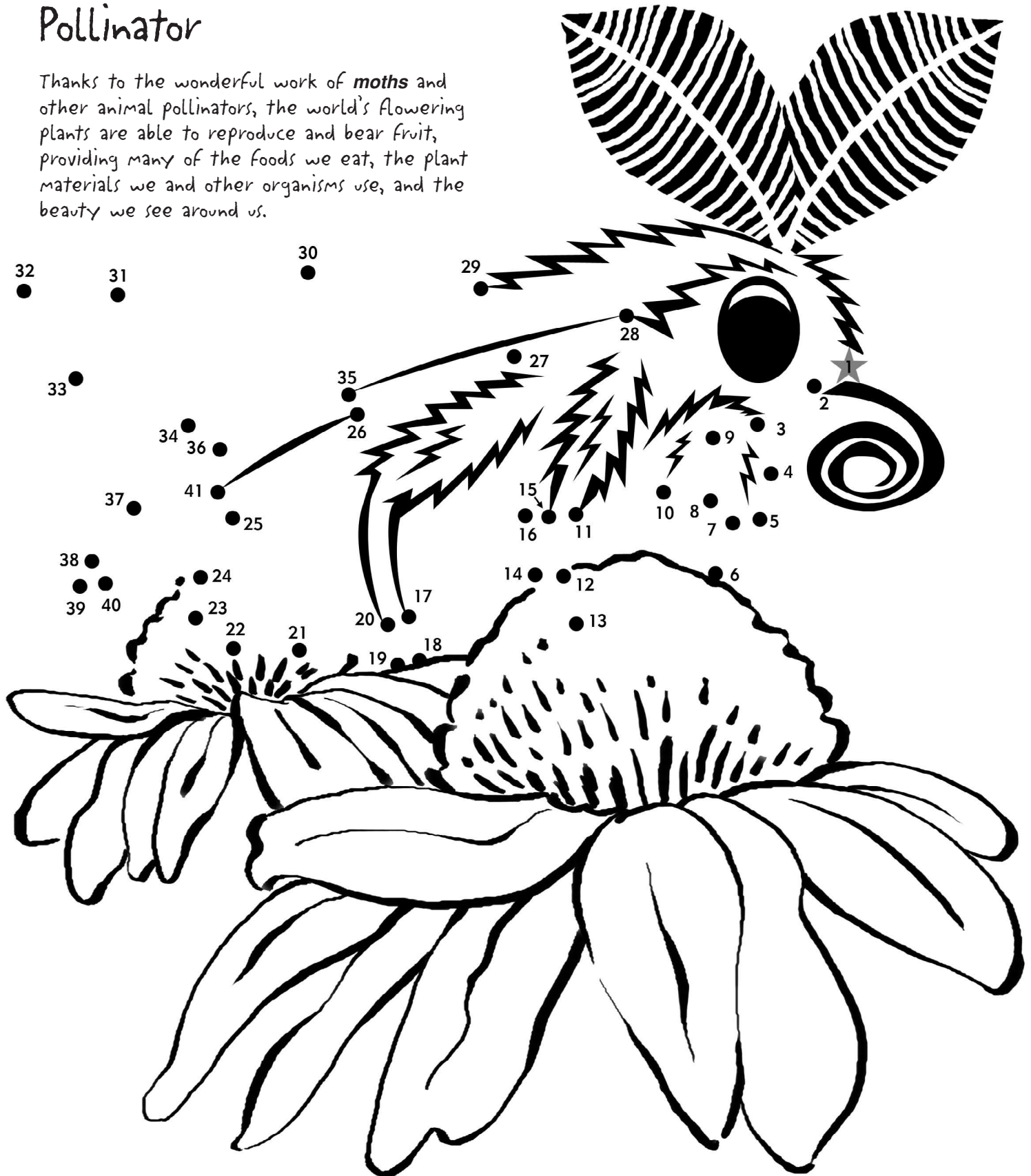

Connect the Dots to Discover the  
**Invasive Species**

Hundreds of new plants, animals and diseases come to the United States from around the world unplanned. These species are called invasive species when they start breeding and become harmful to a habitat's original plants and animals. The **Nutria** came to the U.S. in 1899. This animal is a big environmental challenge for scientists and resource managers.

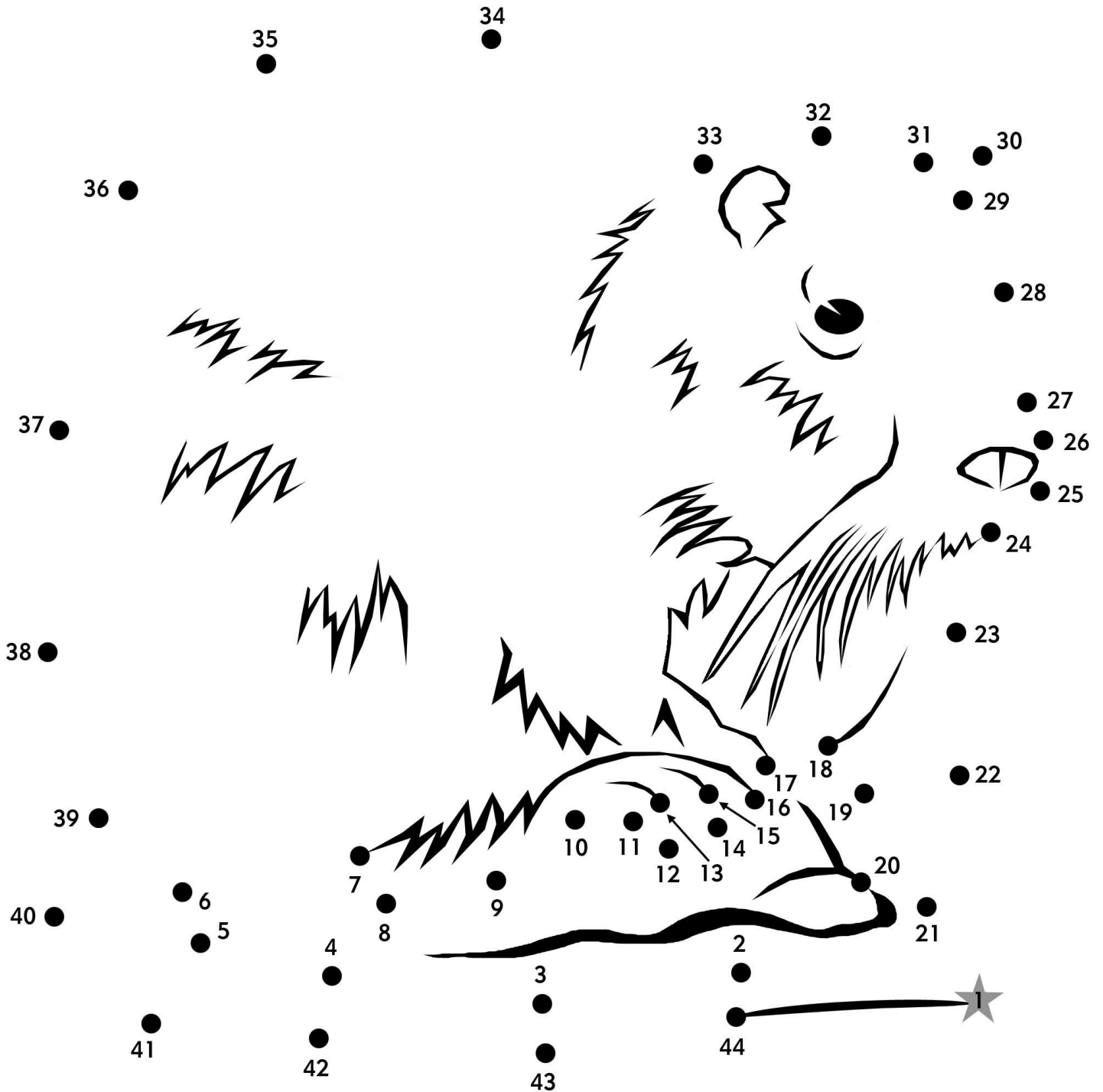

Connect the Dots to Discover the

# Threatened & Endangered Species

Endangered species and threatened species are animals or plants in danger of dying out. The **Pronghorn** is one of over a thousand endangered or threatened species protected under the United States Endangered Species Act.

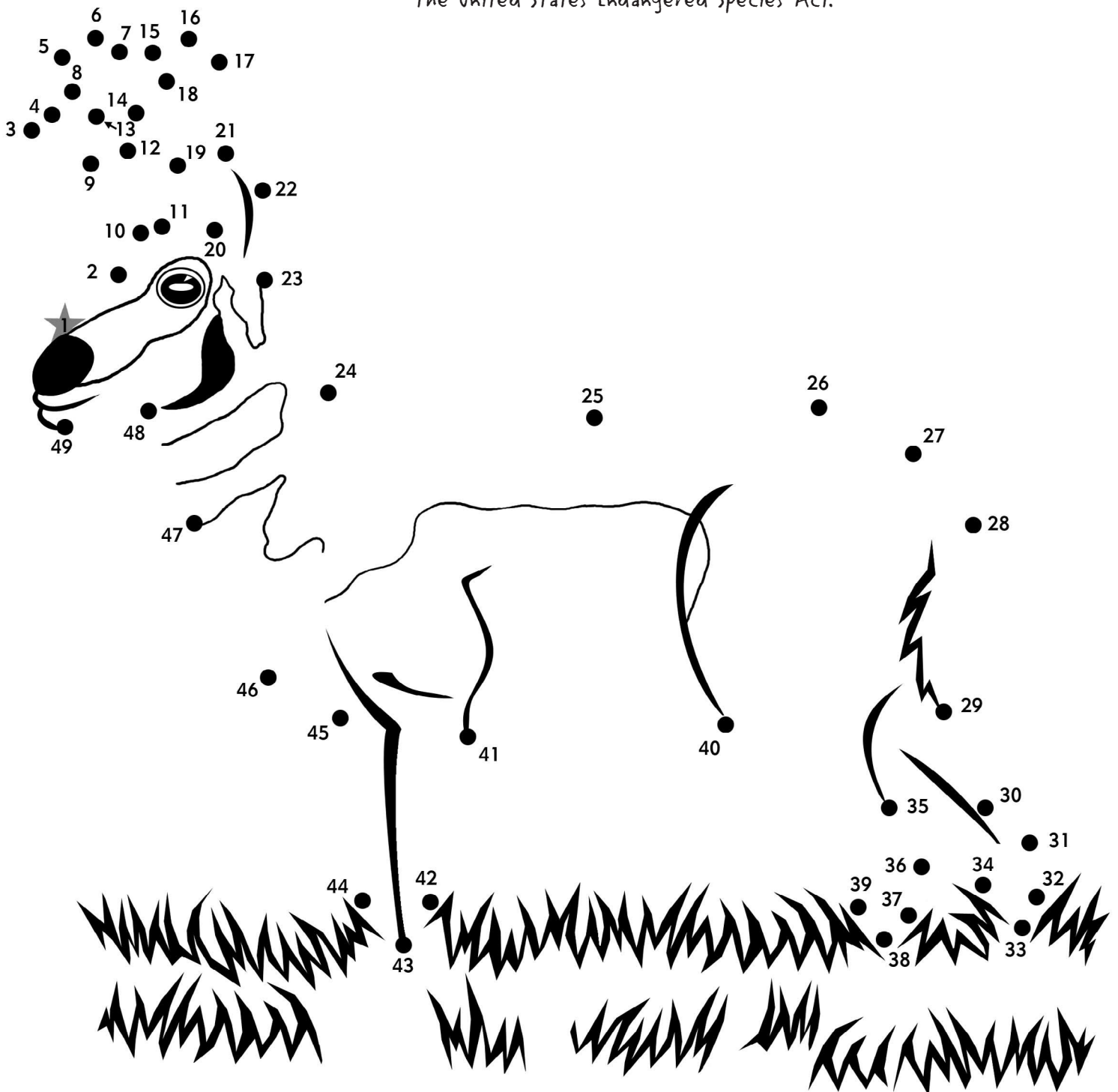

Connect the Dots to Discover the  
**Threatened  
& Endangered  
Species**

Endangered species and threatened species are animals or plants in danger of dying out. The **Stilt** is one of over a thousand endangered or threatened species protected under the United States Endangered Species Act.

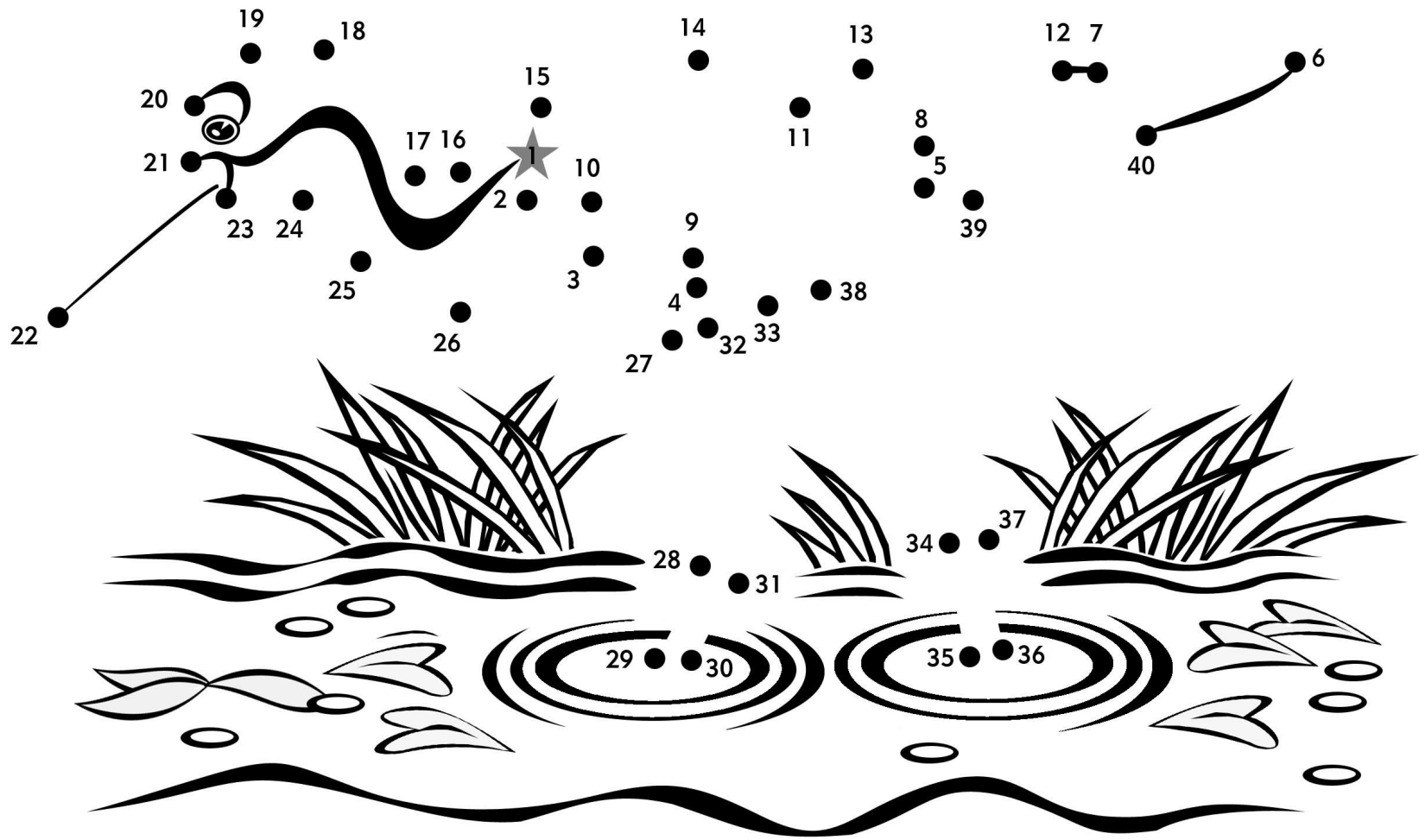



START

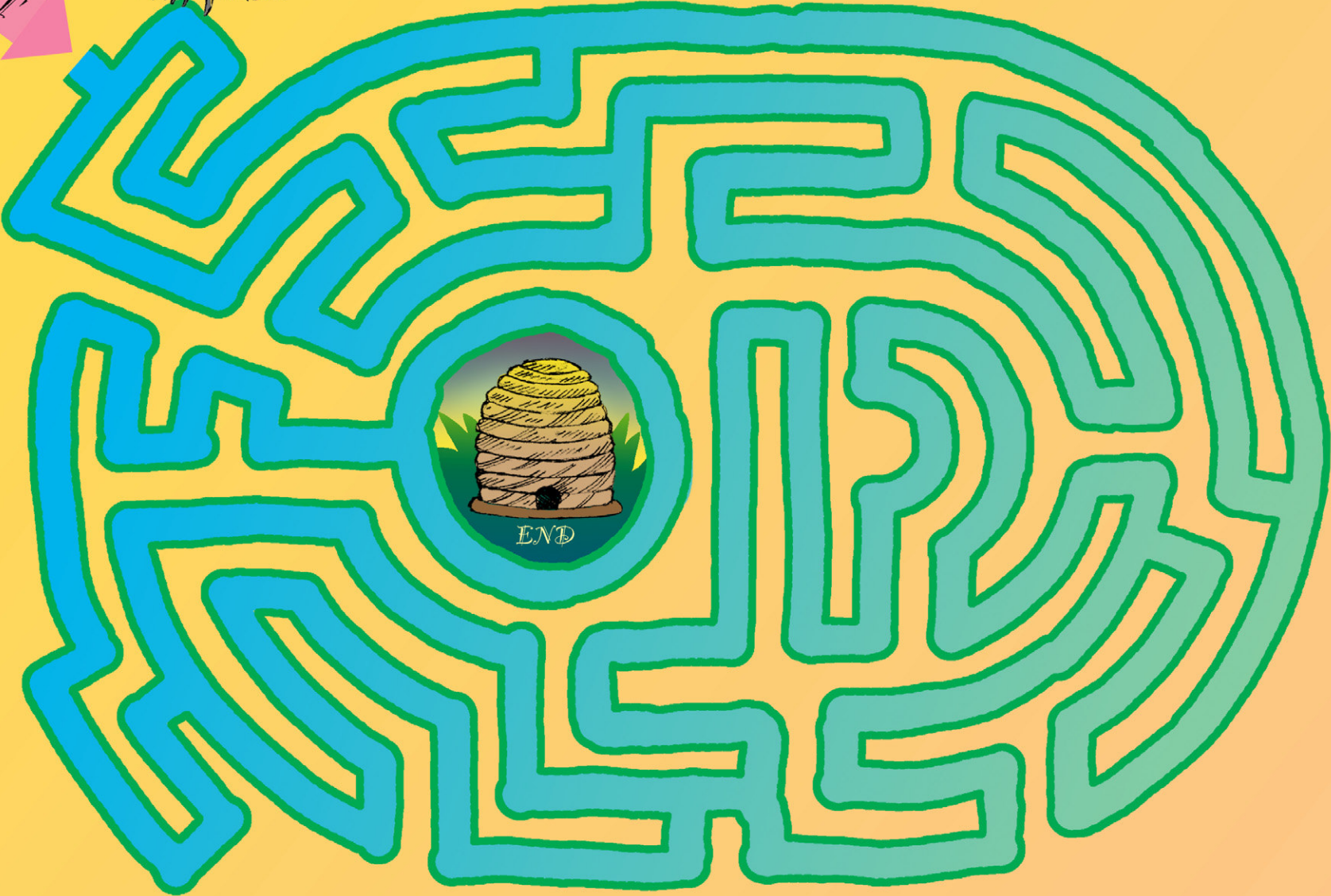

END

# The North American Bluebird Society

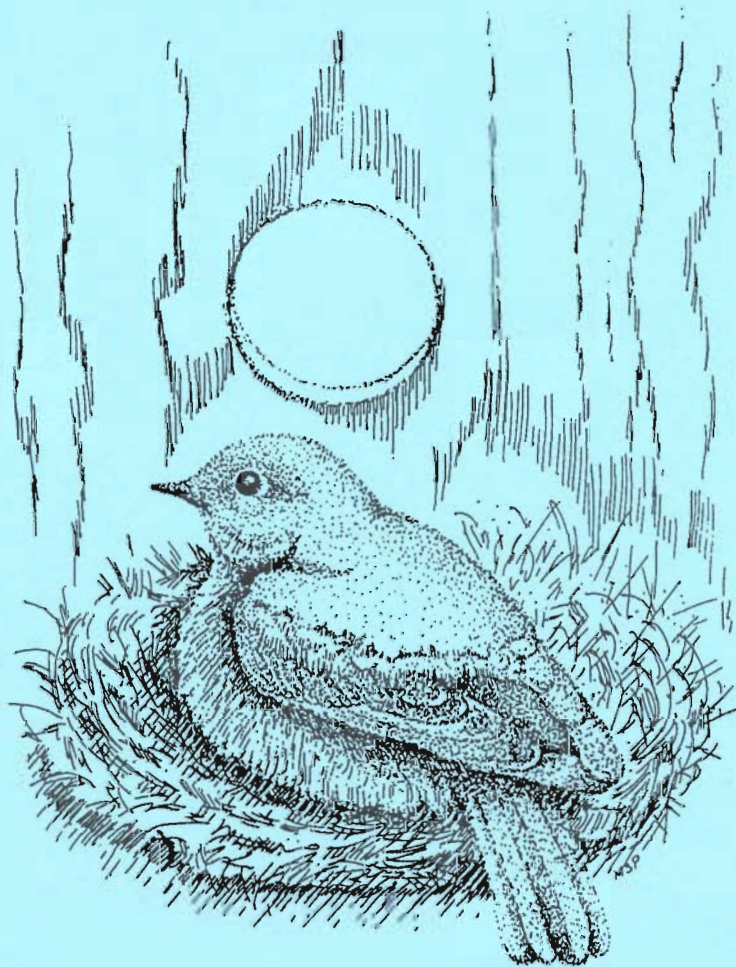

**Educational Packet**

# CONTENTS

Introduction	1
Where Have All the Bluebirds Gone?	2
Range Maps	3-5
Bluebird Behavior	6-8
Wildlife Plantings for Bluebirds	9-11
Starting a Bluebird Trail	12-13
Building a Nesting Box for Bluebirds	14
Nesting Box Plans	15-16
Predator Guards	17
Cavity Nesting Birds	18-19
Vocabulary	20
Coloring Pages	21-23
Bluebird Mobile	24-25
My Fine-Feathered Bluebird Friend	26-27
Sand Painting	28-29
Word Search	30-32
Game One: Musical Nesting Boxes	33-34
Game Two: Answers First, Questions Afterward	35
Further Activities	36
Bibliography	36
Resources Available from The North American Bluebird Society	36

This material is copyrighted by the North American Bluebird Society, Inc. All or portions may be reproduced for educational use only. This package (or portions thereof, including drawings) may not be used for publicity purposes or commercially without the consent of the North American Bluebird Society, Inc.

P.O. Box 43  
Miami, OH 45147

©North American Bluebird Society, Inc., 2007

# INTRODUCTION TO BLUEBIRDS

Bluebirds are one of the few North American birds that are mostly blue in color. At least one of the three **species** of bluebirds is found in every state except Hawaii, as well as in most of Canada and some parts of Mexico. The Eastern Bluebird is also found in **Bermuda**.

The **Eastern Bluebird** is resident east of the Rocky Mountains. The male's head, back, wings, and tail are bright blue. His throat, breast, and sides are rusty. The belly is white. The female resembles the male but is duller and grayer.

The **Western Bluebird** lives in the western part of North America from southern Canada, south into Mexico. The Western Bluebird looks much like the Eastern Bluebird except that its throat is blue. The rusty color of the breast and sides extends over its upper back.

The **Mountain Bluebird**, as its name suggests, likes high elevations. In many places, however, the bird will nest at low altitudes. This bluebird lives mostly in the Rocky Mountain region, ranging as far east as Manitoba, Canada and the Dakotas in the United States. The male Mountain Bluebird is entirely blue except for his white belly. The female is mostly gray. A little blue shows on her wings and tail.

Early settlers looked upon the **bluebird** as the true **harbinger** of spring. They often referred to the bird as the "blue robin" since its colors reminded them of their own robin in Europe. At the turn of the last century, the bluebird was one of the more common songbirds. It nested freely close to human dwellings and in the suburbs of large cities.

Over the past 60 years, the population of the bluebird has steadily declined. They are seldom seen in suburban areas any more and are becoming scarce in most rural areas.

The North American Bluebird Society was founded in 1978. The society's goal is to increase the population of the three bluebird species and that of other cavity nesting birds.

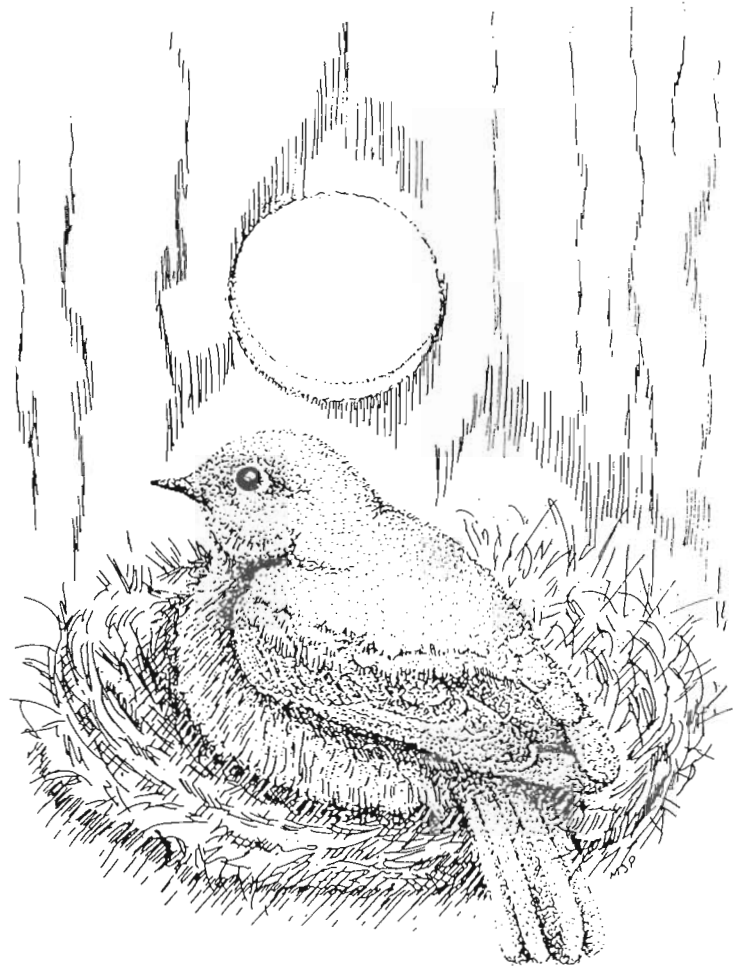

*A female Western Bluebird sits on her nest.*

# WHERE HAVE ALL THE BLUEBIRDS GONE?

Over the years, land has been cleared for housing developments, shopping malls, highways, and cropland. With modernization, the supply of natural cavities that bluebirds and other **cavity nesters** could use has been greatly reduced. This has contributed substantially to the lack of suitable nesting areas for the bluebird. Many old trees have been cut down for firewood. Wooden fence posts have now been replaced with metal posts. Old apple orchards once provided many cavities for bluebirds. Today most orchards are owned by commercial companies that prune dead wood and spray the trees with insecticides.

Woodpeckers are able to **excavate** cavities in trees. They are known as primary cavity nesters. Bluebirds are known as secondary cavity nesters. This means they are unable to excavate a cavity and must rely on finding one in a tree or a fence post.

Bluebirds must also compete with the alien House Sparrow and European Starling for nesting cavities. The sparrow is about the size of a bluebird. It can enter any hole that bluebirds can enter. The House Sparrow is very aggressive and will usually take a cavity away from a bluebird. Bluebirds can never compete successfully with European Starlings for any natural cavity that is large enough for the starling to enter. If starlings are numerous in an area where bluebirds nest, the bluebird usually disappears.

During the summer, bluebirds live mainly on insects. Few insects are available in the winter so that bluebirds depend on many kinds of wild berries for their food supply. The supply of wild berries has decreased over the years. Land has been cleared for highways, shopping malls, and housing developments. The few berries that

are still around are often stripped quickly by large flocks of starlings.

Now that we know some of the reasons why the bluebird population has decreased, what can we do to help them?

The first thing we can do is provide suitable homes by starting a **bluebird trail**. In areas where nesting boxes have been put up in the correct habitat, bluebirds have been increasing. A trail consists of a few, or many, boxes put up in an area. Nesting boxes are spaced 100 yards apart since bluebird families do not want to be close to each other.

Another way we can help the bluebird is by planting trees and shrubs that will provide a supply of winter berries. Many of the trees and shrubs can be planted around your lawns or gardens. By doing this, we will not only help bluebirds, but many other desirable species of wildlife as well.

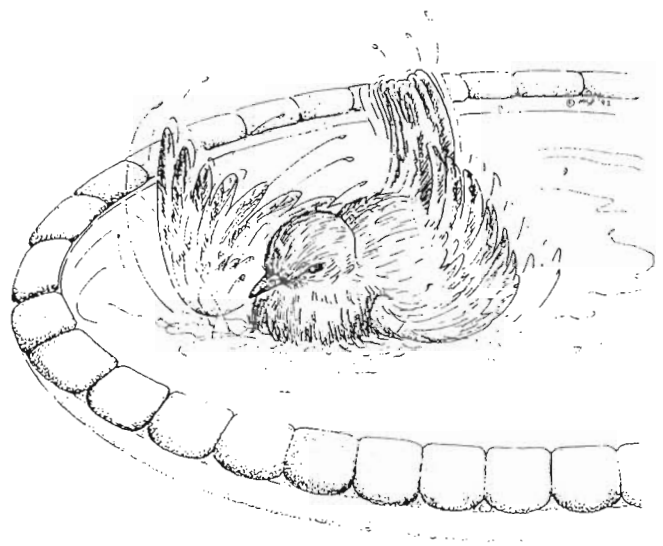

*An Eastern Bluebird enjoys a bird bath.*

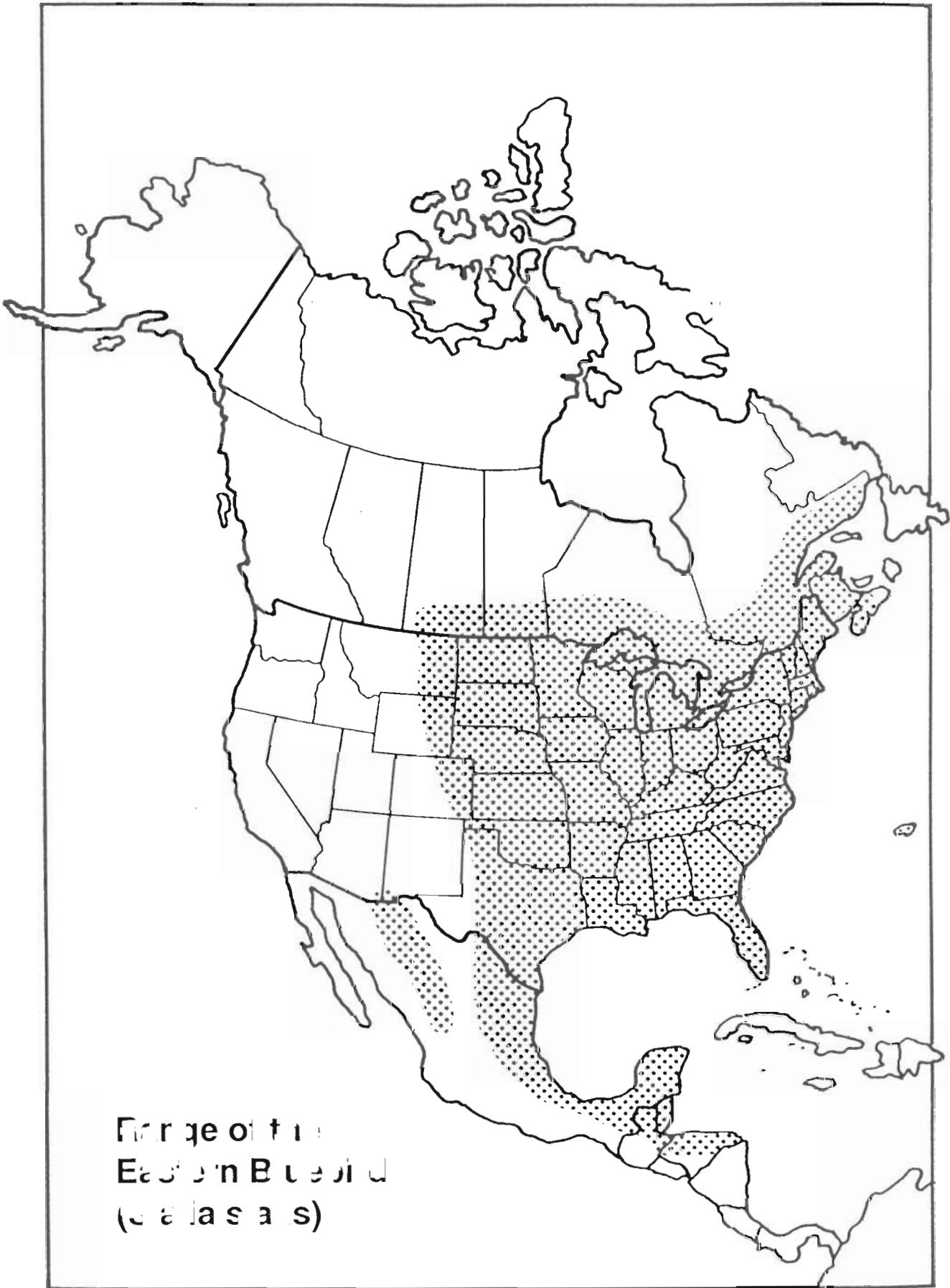

Range of the  
Eastern Bluebird  
(C. a. l. s.)

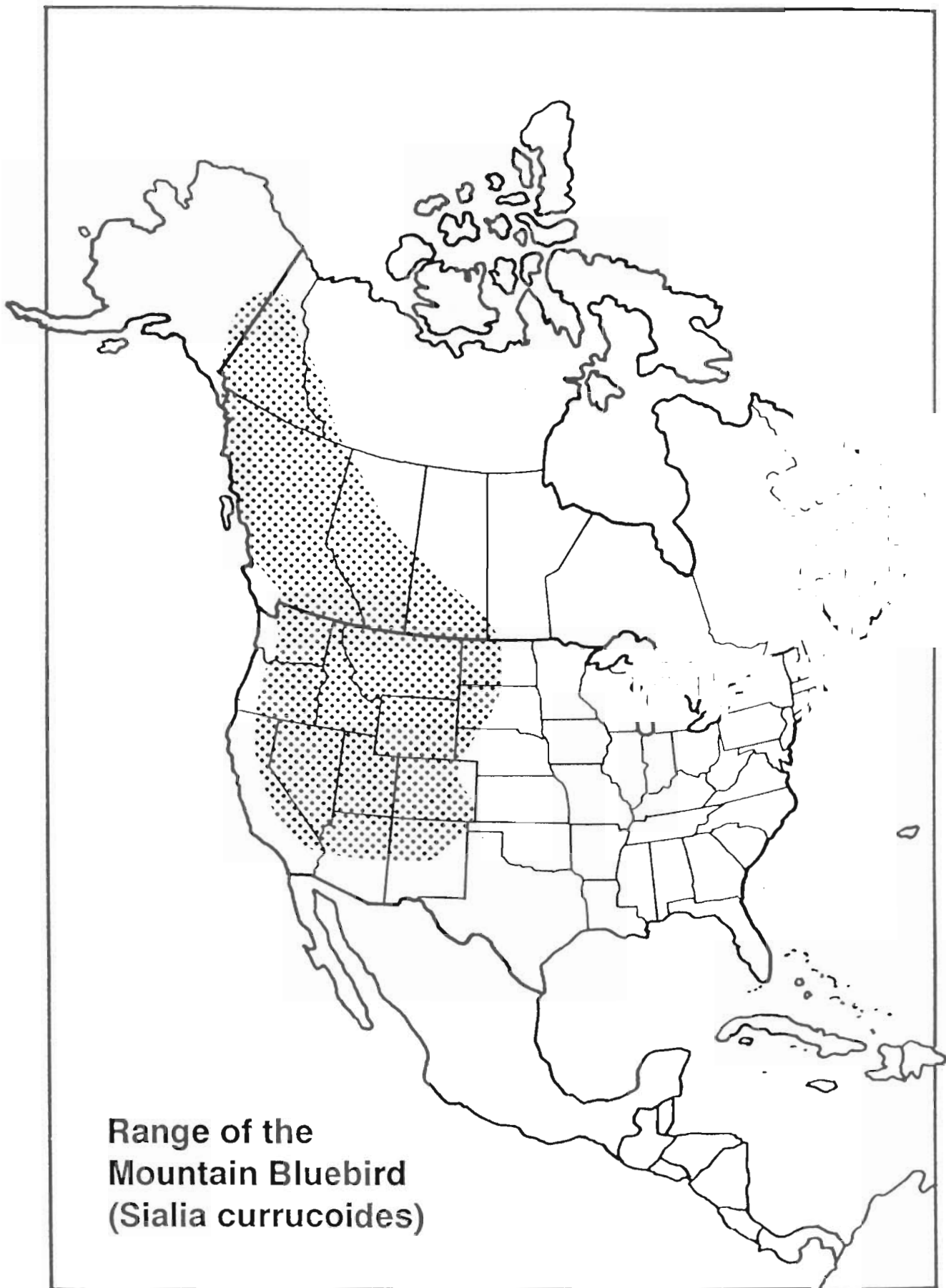

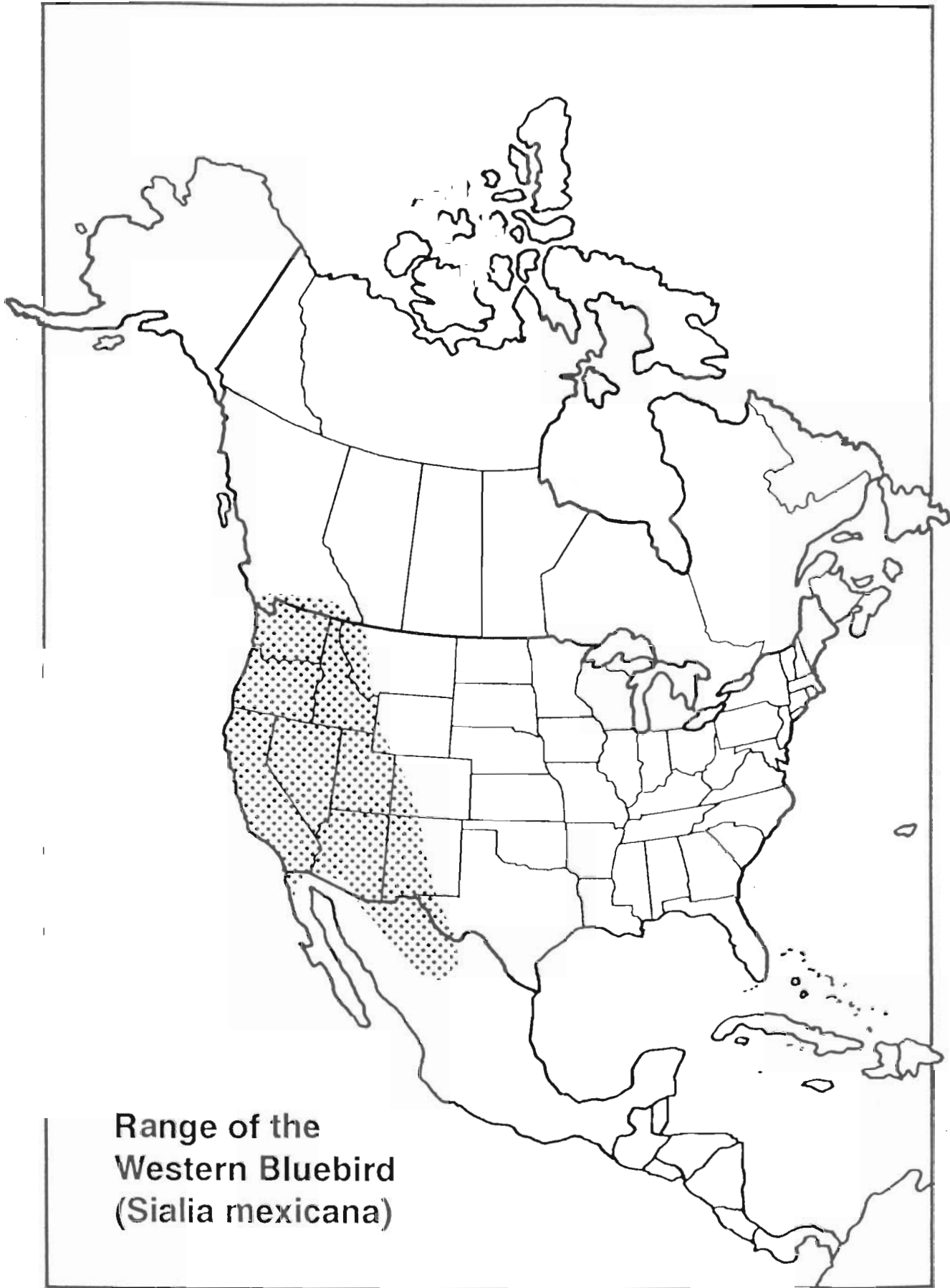

**Range of the  
Western Bluebird  
(*Sialia mexicana*)**

# BLUEBIRD BEHAVIOR

## Migration

Canada Geese are probably one of the first birds we think about when we speak of migration. The geese pass over in large, noisy flocks. Sometimes, hundreds of robins will stop to feed on our lawns for a few days during their long migration trip. Unfortunately, we don't usually see large flocks of bluebirds migrating.

During the fall, in areas where bluebirds migrate, they never seem to be in a hurry to start south. As insects become hard to find, the bluebirds will start moving around searching for berries. At this time a few family groups may join together. Bluebirds seem to drift south slowly, probably as food becomes scarce and the weather gets colder.

Most Eastern Bluebirds spend the winter in the southern half of their breeding range. A few might remain in northern areas, if they can find a suitable supply of wild fruit. Bluebirds may, however, die if an ice storm or heavy snow covers the food supply.

Mountain and Western Bluebirds may migrate to lower elevations or to southern areas in winter. The Mountain Bluebird migrates a longer distance than the other two species. The birds that nested in Alaska will move to areas south of the Canadian border. Those that nested in the southwestern mountains may move as far south as Mexico.

Spring migration starts early for bluebirds. They return to their northern breeding **range** in March or early April.

Bluebird trails have helped increase the bluebird population over the past few years. Once in awhile, someone is lucky enough to see a fairly large group of bluebirds migrating north. As the population continues to increase, we may see larger flocks of bluebirds.

We still have much to learn about bluebird migration. Maybe one of you will become an **ornithologist** and study bluebird migration.

## How Long Do Bluebirds Live?

The first few weeks after bluebirds have **fledged** from the nesting box can be difficult for them. It is at this time that many young birds may die. They must learn to find their own food and to survive on their own. Severe summer storms can soak the feathers of young birds and they will easily become chilled and die.

If young birds survive the first couple of months after fledging, they stand a very good chance of living two or three years.



# BLUEBIRD BEHAVIOR (continued)

Bluebirds sit quietly on a perch, such as a tree limb, a post, or a wire to look for food on the ground. This is the main reason that perching places are so important when you put up a bluebird nesting box. When a bluebird sees **prey**, it will quickly

fly down, catch the food, and return with it to a perch point. Bluebirds can **hover** over the ground, rapidly fluttering their wings, while looking for food. The Mountain Bluebird is much better at hovering than either Eastern or Western Bluebirds.

## Bluebird Postures

Bluebirds use different postures as a way of communicating with each other. You may be able to see this if you watch your nesting boxes. The male bluebird chooses a nesting box that he finds suitable. He then shows

the nesting box to a female and tries to convince her that this is the box they should use. A few of the postures the male uses are shown in the following illustrations.

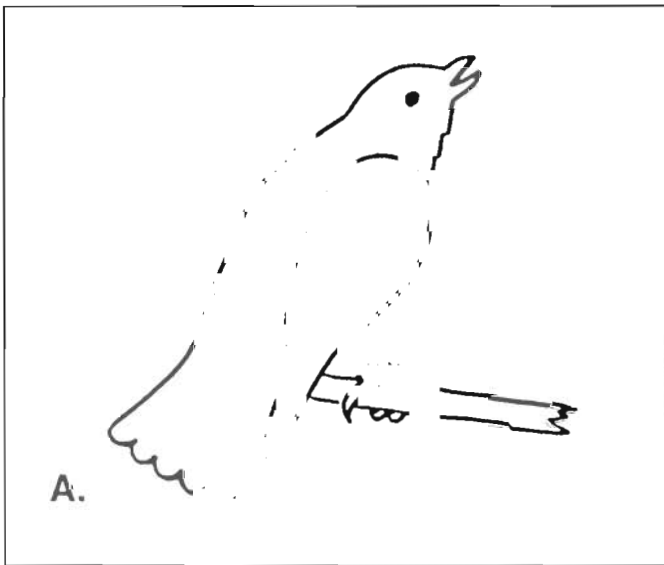

**A.** This is a very common posture. As the female approaches the box, the male droops his wings, raises his bill slightly and spreads his tail. This shows a “mass of blue” to the female.

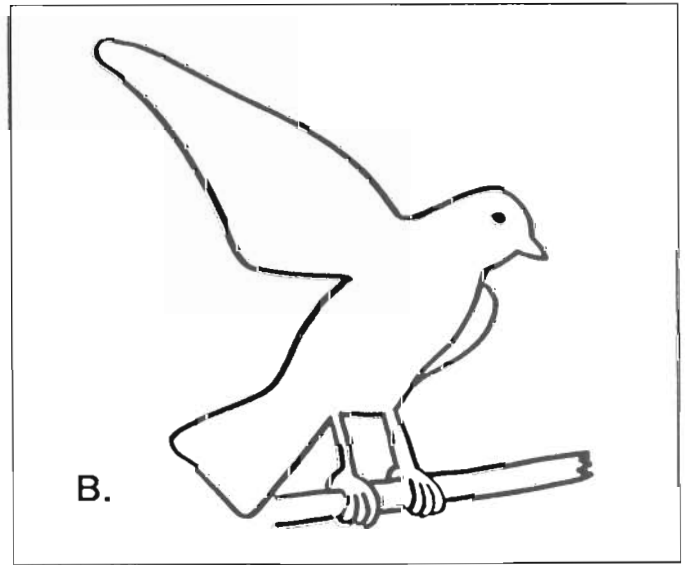

**B.** The wing-lifting posture is a very common sight. The male will show this posture to the female. A bluebird in this posture is a sure sign of spring.

## BLUEBIRD BEHAVIOR (continued)

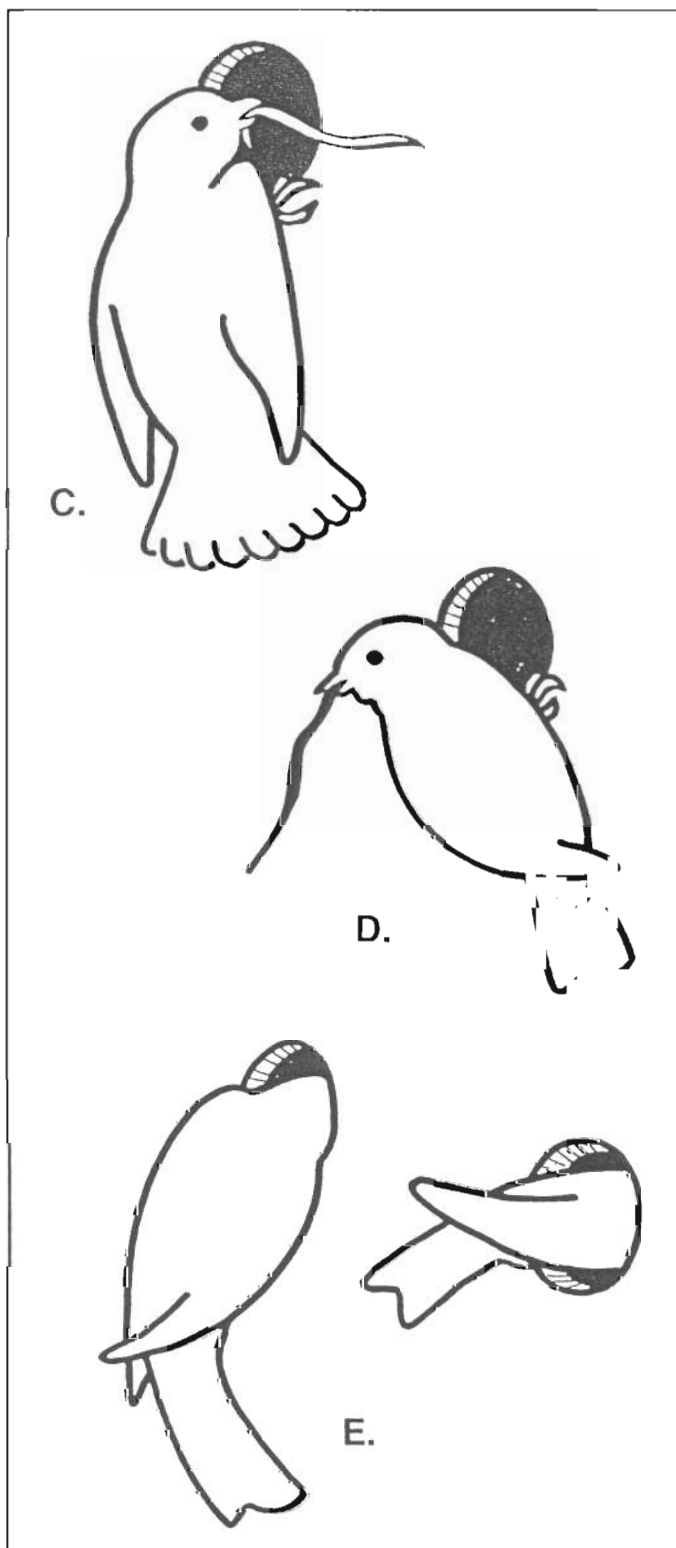

**C, D and E.** With the female usually present, the male will carry nesting material. Often he has already placed nesting material in the box. **Figure C** shows him perched at the hole with his wings and tail spread.

This makes the blue color of his back very noticeable. He often looks around while at the entrance hole, **Figure D**. The male will put his head and shoulders into the box and may rock back and forth. Finally, he usually enters the entrance hole. If the female approves of the nesting box, she will probably examine the box inside and out. This appears to be the signal to the male that she likes the nesting box.

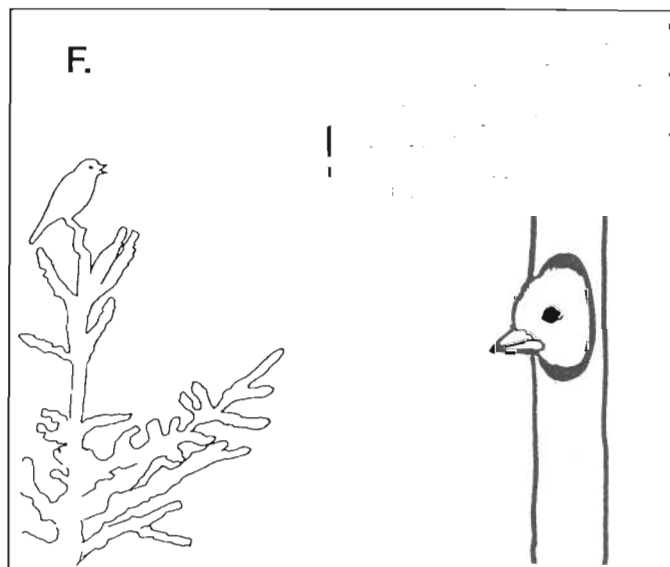

**F.** When baby bluebirds are ready to leave the nesting box, the parents will usually stop feeding them. The parents may sit somewhere nearby and call to the young **nestlings**. The baby bluebirds are now capable of flying from the entrance hole to a nearby perch. Sometimes, they will fly as far as 100 feet on their first flight. The young bluebirds will be reasonably safe from **predators** if they can fly directly to a perch and not to the ground. This is one reason that it is so important to face the nesting box toward a tree or shrub.

# WILDLIFE PLANTINGS FOR BLUEBIRDS

Many areas within the bluebirds' range no longer have enough fruit-producing trees or shrubs. Development has destroyed many of the native plants. In order to increase the bluebird population, we need to make sure they can survive through the winter. We can do this by providing the proper food.

Bluebirds are basically **insectivores**. During the summer, their diet is almost entirely insects, worms and small spiders. All three species of bluebirds like crickets and grasshoppers. Since they prefer to capture prey from the ground, it is not surprising that this food makes up a large part of their diet. The bluebird serves a useful purpose for us by controlling harmful insects.

During late fall and winter, insects become scarce. It is then necessary for bluebirds to start eating fruit. This is not a preferred food, but bluebirds can survive until insects are once again easy to find. Bluebirds rarely eat the fruit of the plants that we grow for humans to eat.

Many of the plantings can be worked into the landscape around your home. Not only will they look attractive, but they will provide food, shelter, and nesting sites for many kinds of wildlife.

Some of the plants on this list such as pokeweed, poison ivy, and mistletoe, are often called weedy plants. These will not be found in a nursery. If they are found growing, they should be left undisturbed, whenever possible, to provide food for birds. Be sure to consult local nurseries to find out which plants are best for your area. The following is a list of plants which bear good supplies of fruits that bluebirds like to eat.

**Table 1.** Trees and shrubs having high wildlife values, most of which hold their fruit well into the winter season.

**Table 2.** Trees and shrubs having high wildlife values, most of which carry fruit in summer and autumn. Many species are valued for human consumption.

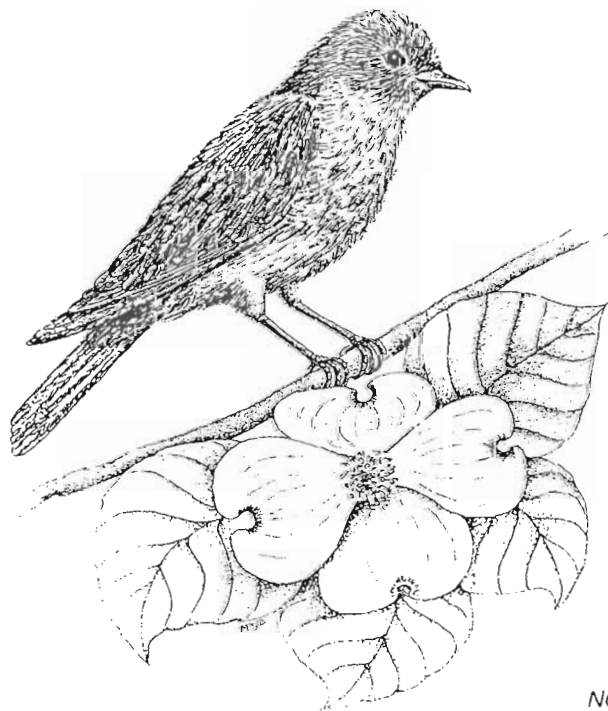

*An Eastern Bluebird perches on the branch of a dogwood tree.*

## TABLE ONE

Trees and shrubs having high wildlife values, most of which hold their fruit well into the winter season.

<i>Aronia arbutifolia</i>	Red Chokeberry
<i>Celastrus scandens</i>	American Bittersweet
<i>Celtis occidentalis</i>	Hackberry
<i>Cornus florida</i>	Flowering Dogwood
<i>Cotoneaster microphylla</i>	Small-leaved Cotoneaster
<i>Crataegus phaenopyrum</i>	Washington Hawthorn
<i>Crataegus tomentosa</i>	Blackthorn
<i>Ilex decidua</i>	Deciduous Holly Possumhaw
<i>Ilex glabra</i>	Inkberry
<i>Ilex opaca</i>	American Holly
<i>Ilex verticillata</i>	Common Winterberry
<i>Juniperus scopulorum</i>	Western Red Cedar
<i>Juniperus virginiana</i>	Eastern Red Cedar
<i>Ligustrum vulgare</i> *	Privet
<i>Lindera benzoin</i>	Spicebush
<i>Lonicera japonica</i> *	Japanese Honeysuckle
<i>Lonicera maackii</i> *	Rem Red Honeysuckle
<i>Myrica pensylvanica</i>	Northern Bayberry
<i>Nyssa sylvatica</i>	Sour Gum
<i>Parthenocissus quinquefolia</i>	Virginia Creeper
<i>Phoradendron serotinum</i>	Mistletoe
<i>Pyracantha</i> sp. *	Pyracantha
<i>Rhus copallina</i>	Small Sumac
<i>Rhus glabra</i>	Smooth Sumac
<i>Rhus typhina</i>	Staghorn Sumac
<i>Rosa carolina</i>	Pasture Rose
<i>Rosa multiflora</i> *	Multiflora Rose
<i>Sorbus americana</i>	American Mountain-Ash
<i>Symphoricarpos orbiculatus</i>	Coralberry
<i>Toxicodendron radicans</i>	Poison Ivy
<i>Viburnum lentago</i>	Nannyberry
<i>Viburnum trilobum</i>	Highbush Cranberry

\* non-native plant

## TABLE TWO

Trees and shrubs having high wildlife values, most of which carry fruit in summer and autumn. Many species are valued for human consumption.

<i>Amelanchier</i> sp.	Service Berry
<i>Berberis thunbergii</i> *	Japanese Barberry
<i>Cornus alternifolia</i>	Alternate-leaf Dogwood
<i>Cornus amomum</i>	Silky Dogwood
<i>Cornus racemosa</i>	Gray Dogwood
<i>Cornus rugosa</i>	Roundleaf Dogwood
<i>Cornus stolonifera</i>	Red-osier Dogwood
<i>Cornus mas</i> *	Cornelian Cherry
<i>Cornus kousa</i> *	Kousa Dogwood
<i>Elaeagnus angustifolia</i> *	Russian Olive
<i>Elaeagnus umbellata</i> *	Autumn Olive
<i>Gaylussacia baccata</i>	Black Huckleberry
<i>Malus</i> sp. *	Apples
	Crabapples
<i>Morus rubra</i>	Red Mulberry
<i>Morus alba</i> *	White Mulberry
<i>Phytolacca americana</i>	Pokeweed
<i>Prunus pensylvanica</i>	Pin Cherry
<i>Prunus virginiana</i>	Common Chokecherry
<i>Ribes americanum</i>	American Black Currant
<i>Rubus allegheniensis</i>	American Blackberry
<i>Sambucus canadensis</i>	American Elder
<i>Sambucus pubens</i>	Scarlet Elder
<i>Sorbus aucuparia</i> *	European Mountain-Ash
<i>Symphoricarpos albus</i>	Common Snowberry
<i>Vaccinium angustifolium</i>	Lowbush Blueberry
<i>Vaccinium corymbosum</i>	Highbush Blueberry
<i>Viburnum acerifolium</i>	Mapleleaf Viburnum
<i>Viburnum alnifolium</i>	Hobblebush
<i>Viburnum dentatum</i>	Arrowwood
<i>Vitis</i> sp.	Wild Grape

\* non-native plant

# STARTING A BLUEBIRD TRAIL

A bluebird trail consists of a series of nesting boxes placed along a path or road. Here are a few tips to get you started.

1. Select proper **habitat**. Open rural country with scattered trees and low or sparse ground cover is best. Suitable habitat also includes a perch such as a fence, wires, or dead branches where bluebirds may perch to search for food. Look for these when you are selecting a location for your nesting boxes. If bluebirds do not like the habitat, they probably will not use your boxes.
2. Avoid brushy and heavily wooded areas. This is the habitat of the House Wren.
3. Avoid areas where the House Sparrow is abundant.
4. Avoid areas of heavy pesticide use.
5. Mount nesting boxes four feet or more from the ground, preferably on smooth pipes or posts.
6. Mount boxes so that the entrance hole faces a tree or shrub. This allows the young bluebirds to fly directly to a branch when they leave the nesting box. This will keep them off the ground, away from predators.
7. Boxes should be spaced at least 100 yards apart.
8. Protect boxes against snakes, raccoons, feral cats, and other predators. Suggestions for protecting your nesting boxes are shown in another section of this package.
9. **Monitor** the boxes, if possible, at least once a week during the nesting season. Use the enclosed monitoring sheet as an example.

10. Always remove House Sparrow nests immediately. Remove bluebird nests and those of other birds as soon as the young birds have fledged.
11. Inspect boxes in late winter. Clean and repair, if necessary.
12. Boxes should be mounted in pairs in areas where Tree Swallows are abundant. Boxes can be mounted back to back or up to five feet apart. This provides nesting sites for both species and helps to prevent competition between them. Different species of birds usually do not mind nesting together.

Do not be too discouraged if your nesting boxes are not used the first year. If bluebirds have not normally been in the area, it may take them a few seasons to find your new box. Bluebird trails have been an extremely effective method of reestablishing the bluebird population. This is a rewarding hobby for people of all ages.



*Eastern Bluebird nestlings huddle together in their nest.*

# BUILDING A NESTING BOX FOR BLUEBIRDS

The most important thing we can do to help bluebirds is to provide them with nesting boxes. Bluebirds are not too particular about the cavity they use, as long as it is in a suitable habitat.

Wood is the best material to use for nesting boxes. Any exterior grade wood, even soft lumber, can be used if it is not warped or split. Wood should be at least 3/4 inch thick to provide proper insulation.

Many bluebirds start their first nest in April. In some areas, nights can be cold and snowstorms are still possible. The 3/4 inch lumber will help to keep the inside of the box warm. The thicker boards will also help keep the box cool on hot summer days.

The depth of the box, or the distance from the opening to the bottom, should be about 10 inches. A deep box provides greater protection from predators that might try to reach inside. The inside of the front panel should always be rough. This can be accomplished by using a nail or a screwdriver to scratch the board. The rough front will help nestlings climb out when they are ready to leave the box.

The most important dimension of a nesting box is the entrance hole. Eastern Bluebirds can easily manage to enter a nesting box with a 1-1/2 inch opening. Mountain Bluebirds are a slightly larger species and require an opening of 1-9/16 inches. Great care must be taken when making the 1-9/16 inch opening. It is very important for the opening to be exact, since anything larger will permit the alien European Starling to use the box. Many areas of the West have both Mountain and Western Bluebirds nesting on the same trail. If you are starting a trail in those areas, you must use the 1-9/16 inch entrance.

Not only does the Mountain Bluebird require a larger entrance, but they also prefer a larger nesting box. They usually have larger broods and the bigger box provides more room for the nestlings.

Nesting boxes should be made so that they can be opened easily. Boxes should be monitored once a week to check the bluebirds' progress. Bluebirds usually nest twice a season, sometimes three times. When the first nestlings have fledged, the box should be cleaned. Remove the old nest. Often the pair of bluebirds will start a new nest.

Complete nesting box plans are included in this package. The plans show one box opening from the top and the other nesting box opening from the side. Your box can be made to open the way that you like best. Bluebirds do not care how the box opens, so choose the style that you prefer.

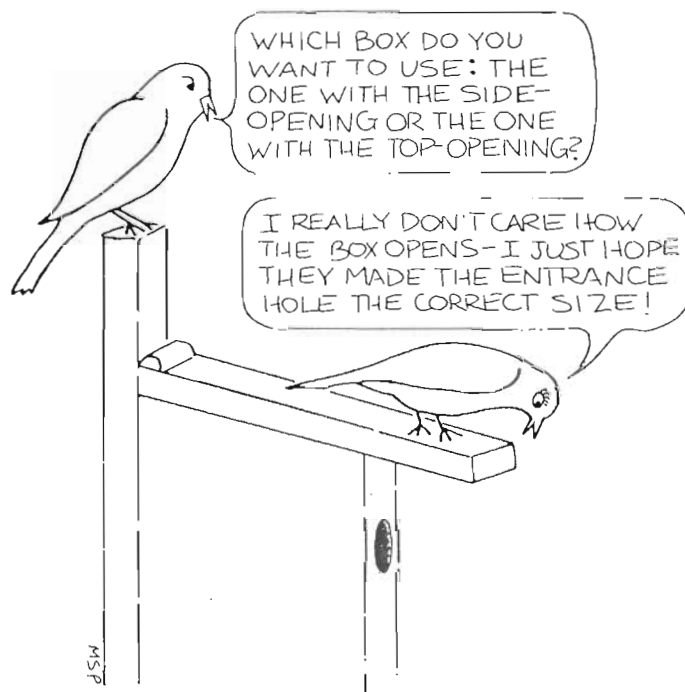

# PLANS FOR A WESTERN AND MOUNTAIN BLUEBIRD NESTING BOX

Dimensions shown are for boards 3/4" thick.

Use 1-3/4" galvanized siding nails or aluminum nails.

Pivot nails must be located exactly opposite each other as shown for proper opening of side board.

Cut top edges of front and back boards at slight angle to fit flush with top board.

Cut 3/8" off each corner of bottom board as shown.

Insert bottom board so that the grain of the wood runs from front to rear of box.

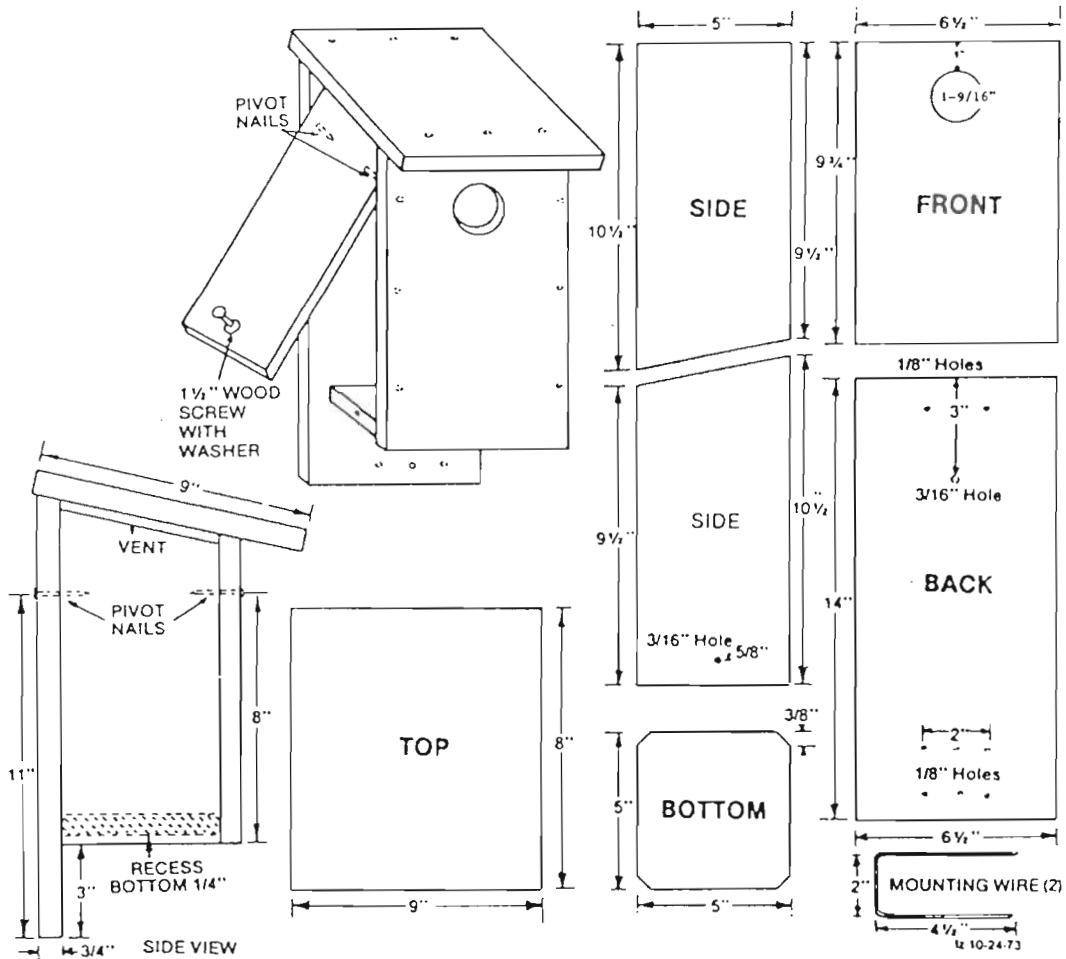

THIS BOX PLAN MAY BE ADAPTED TO TOP OPENING.

# EXAMPLES OF SIMPLE PREDATOR GUARDS FOR BLUEBIRD NESTING BOXES

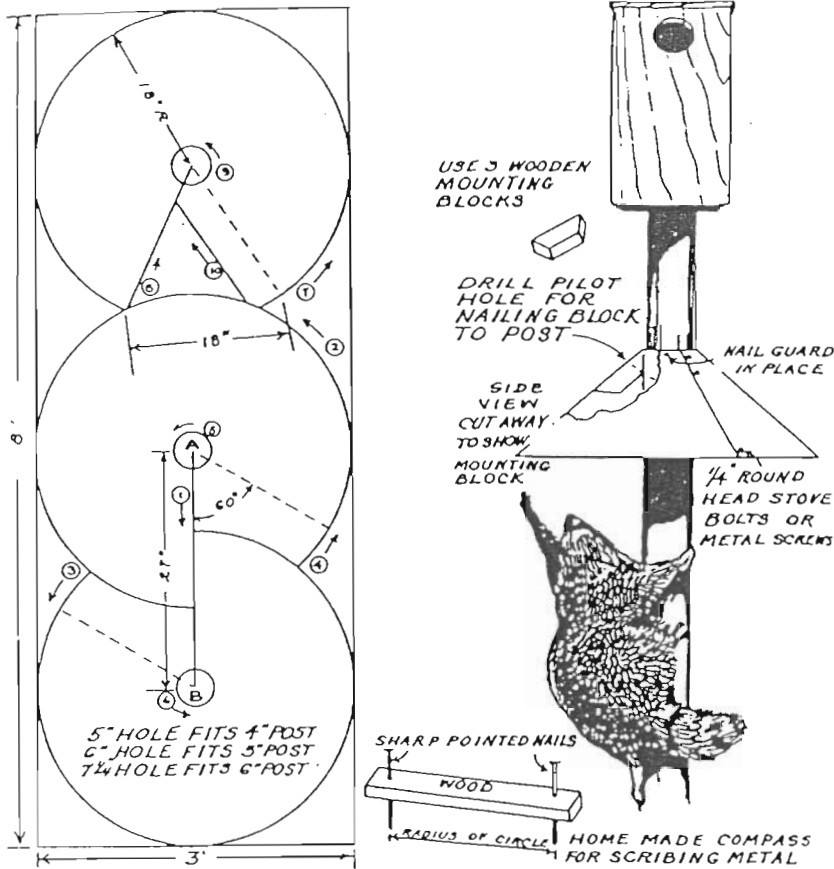

## Conical sheet metal guard for protecting nest structures from predators

At left is layout for cutting three predator guards from a 3 by 8-foot sheet of 26-gauge galvanized metal. When installing the guard, overlap cut edge to dotted line. See hole sizes. To facilitate cutting (on solid lines only) follow sequence of numbers. Make circular cuts in counterclockwise direction. To make initial cut on line A-B, make slot at A with a cold chisel for inserting shears. (Courtesy of U.S. Fish and Wildlife Service)

Three to four inches of lithium grease applied to metal posts, is effective in discouraging climbing predators

## Predator Control

The population of raccoons has greatly increased over the past years. They can raid a nesting box and will eat the eggs, nestlings, or adults. Once a raccoon learns that nesting boxes provide a free meal, it sometimes raids all the boxes on a trail. Feral cats can cause the same problem to nesting boxes. This seems to be more of a problem in the western ranges of the bluebird. It is very important that you try to prevent raccoons and other climbing predators from reaching the nesting boxes.

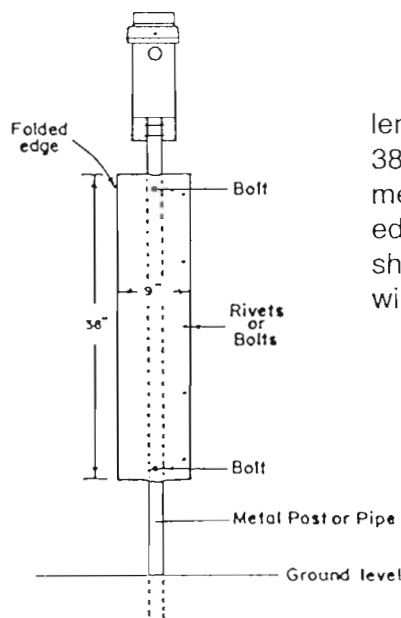

"Sandwich Type" Sheet Metal Predator Guard

## Predator guard made from sheet aluminum 38" x 18"

The sheet is folded tightly lengthwise to form a double panel 38" x 9". This is placed around the metal support post and the free edges riveted or bolted together as shown. The guard is then bolted or wired securely to the post.

# CAVITY NESTING BIRDS

Many other cavity nesters that are both desirable and beneficial may also use your nesting boxes. Their populations have not decreased as much as that of the bluebird, but they too need our help. Learning to identify each bird's nest can be difficult at first. With some experience, nest identification becomes easier and very interesting. One of the easiest ways to learn is to watch the nesting box from a distance. This way you will be able to see what kind of bird enters the box.

In many areas, swallows will be the chief competitor of bluebirds for nesting sites. Tree Swallows can be found in many northern states and in most of Canada. The Violet-green Swallow's range is the West Coast region and the Rocky Mountains. Swallows are known as **insectivores**. This means their diet consists of insects. They are real acrobats in the air and catch all their food while flying. They are beautiful birds and will eat many harmful insects. Swallows are faced with the same general problems that trouble bluebirds. Their population has not dropped as much as the bluebirds'. Swallows also need our help.

Nests of the following birds are those that you will find most often in your nesting boxes.

**Bluebirds**—The nests of all three bluebird species are quite similar. The nest is neatly constructed of dry grass, if it is available. Near a pine woods, the nest may be made almost entirely of pine needles. Sometimes grasses and pine needles are both used. Other plant material may be used if it is all that is available. The 4-5 eggs (sometimes 3-7) of the Eastern Bluebird are pale blue and unmarked. The 4-6 eggs (sometimes 3-8) of the Western Bluebird are like those

of the Eastern. The 5-6 eggs (sometimes 4-8) of the Mountain Bluebird are pale blue to bluish-white, paler than those of the other bluebirds. Their eggs are also slightly larger. An occasional bluebird of any species lays pure white eggs. The **incubation** period for bluebird eggs is usually about 14 days. After the eggs hatch, the nestlings are fed small, soft insects for a few days. The nestlings grow quickly. They will be ready to leave the nest when they are 18-20 days old. By this time, the nestlings are already being fed grasshoppers and hard beetles.

**House Wren**—House Wrens build their nests largely of coarse twigs. They usually fill the nesting box almost completely. Nest cups are lined with fine plant material and, often, feathers. The 5-8 eggs are heavily spotted with reddish-brown.

**Swallows**—Tree Swallow nests are made of grass and other plant material. They are almost always lined with feathers. The 4-6 eggs (sometimes more) are pure white and a little smaller than bluebird eggs. The nest of the Violet-green Swallow of the Rocky Mountains and Pacific Coast region is similar to that of the Tree Swallow.

**Chickadees**—The chickadees that are most likely to be found in bluebird boxes are the Carolina Chickadee of the southeastern United States, the Black-capped Chickadee of the northern half of the United States and most of Canada, and the Mountain Chickadee of the Rocky Mountain region. Chickadee nests vary somewhat depending on the material available. A typical nest includes moss, very fine plant fibers, and animal hair. Hair from family pets or lint from clothes dryers is often used. Chickadees

# CAVITY NESTING BIRDS (continued)

take great care in building their nests. The 5-8 eggs, sometimes more, have a dull white background heavily spotted with light or dark reddish-brown.

**House Sparrow**—House Sparrow nests are made of straw, plant stems, and rubbish such as paper, string, or cloth. They are lined with feathers, hair, or wool. Unlike bluebird nests, sparrow nests are built

high up along the side of the box. They are sometimes domed over. The 4-7 eggs are a dull white color rather heavily speckled with shades of gray, black, brown, or purplish-brown. House Sparrow nests should be removed as often as necessary. These alien birds should never be permitted to raise their broods in bluebird nesting boxes.

---

## CUT-AWAY VIEWS OF NESTING BOXES

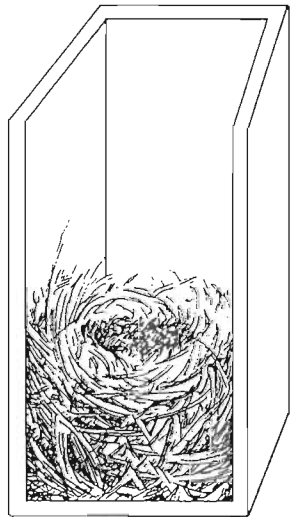

Eastern Bluebird Nest

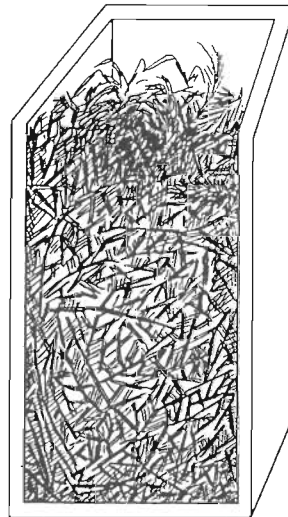

House Wren Nest

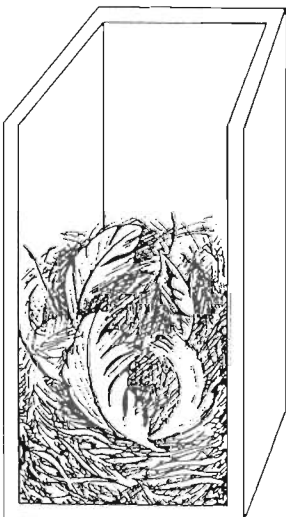

Tree Swallow Nest

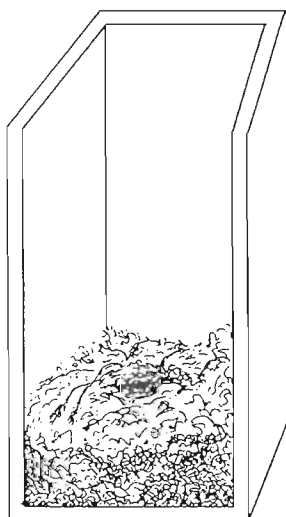

Carolina Chickadee Nest



House Sparrow Nest

# VOCABULARY

**BERMUDA**—a small tropical island located in the Atlantic Ocean, 600 miles east of North Carolina

**BLUEBIRD**—any of three species of the genus *Sialia*: eastern (*S. sialis*), western (*S. mexicana*), and mountain (*S. currucoides*)

**BLUEBIRD TRAIL**—network of nesting boxes set up in suitable habitat

**CAVITY NESTER**—those birds which nest in a hole, either natural or man-made

**EXCAVATE**—to make a hole

**FERAL**—wild; not tame

**FLEDGLING**—a young bird which has recently left the nest

**HABITAT**—the area where a population is usually found

**HARBINGER**—someone who goes first

**HOVER**—to remain suspended near one place in the air

**INCUBATION**—the process of keeping the eggs warm so that they will hatch

**INSECTIVORE**—an animal whose diet consists mainly of insects

**MONITOR**—to look inside boxes on a regular basis

**NESTLING**—a young bird still in the nest

**ORNITHOLOGIST**—someone who studies birds

**PREDATOR**—any animal that grabs another for food

**PREY**—any animal captured by another for food

**RANGE**—the geographic region in which a particular species lives

**SPECIES**—a group of birds or animals of a particular kind

**SIALIA**—genus name of bluebirds; member of the thrush family

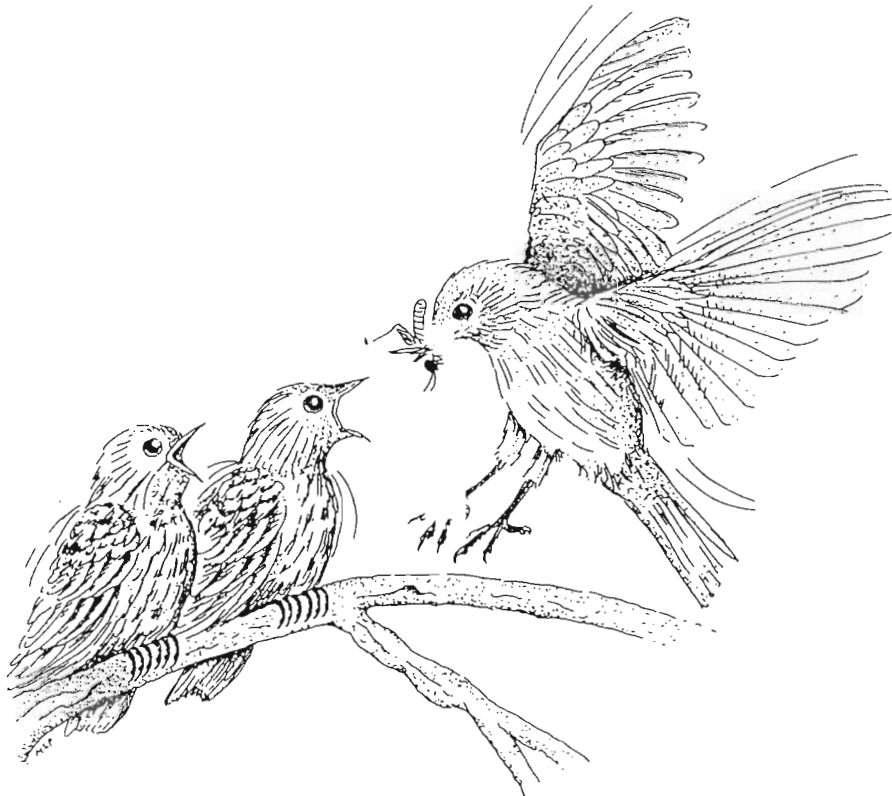

A male Mountain Bluebird brings a grasshopper to two fledglings.

# EASTERN BLUEBIRD

COLORING PAGE

*Sialia sialis*

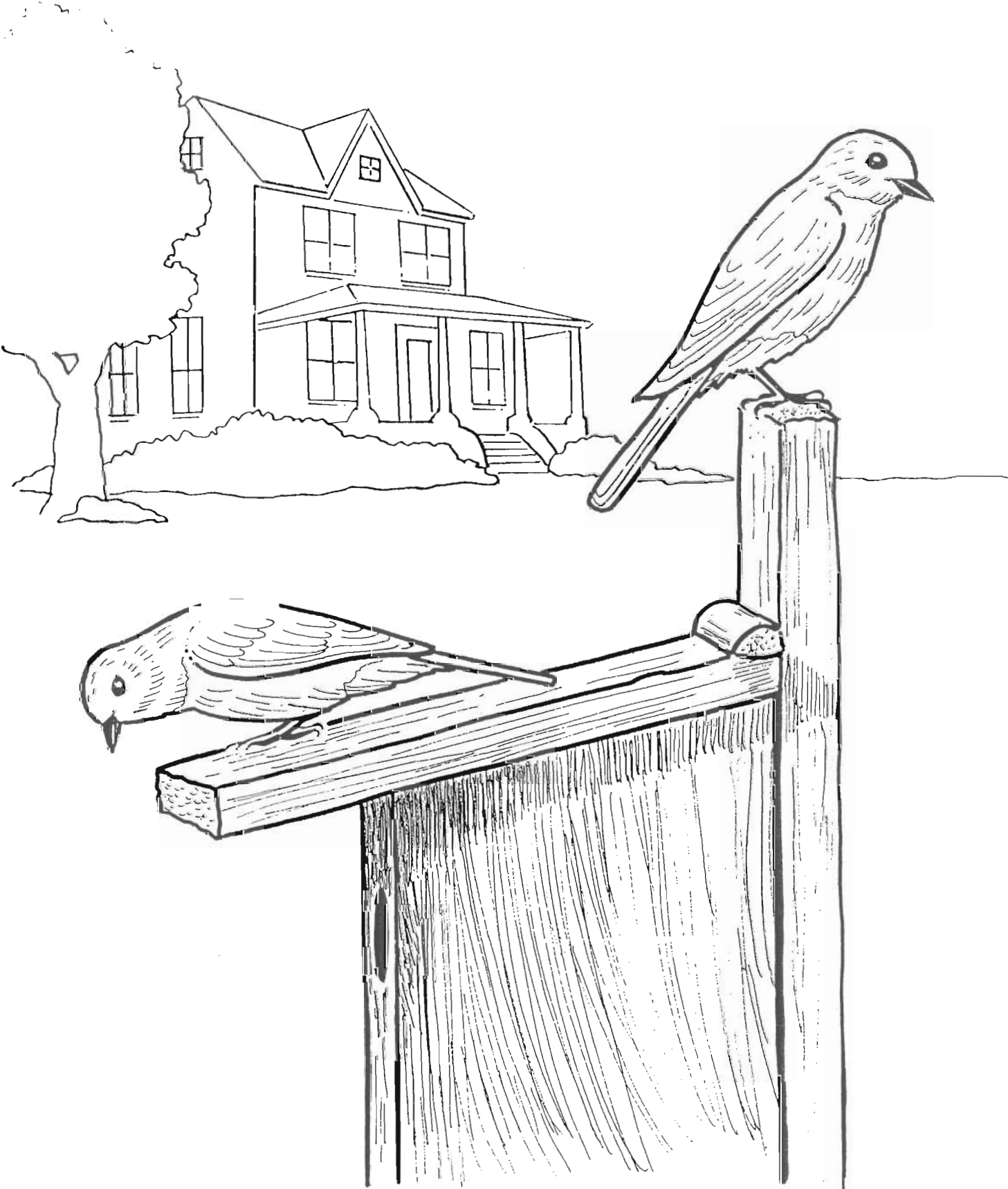

# MOUNTAIN BLUEBIRD

*Sialia currucoides*

COLORING PAGE

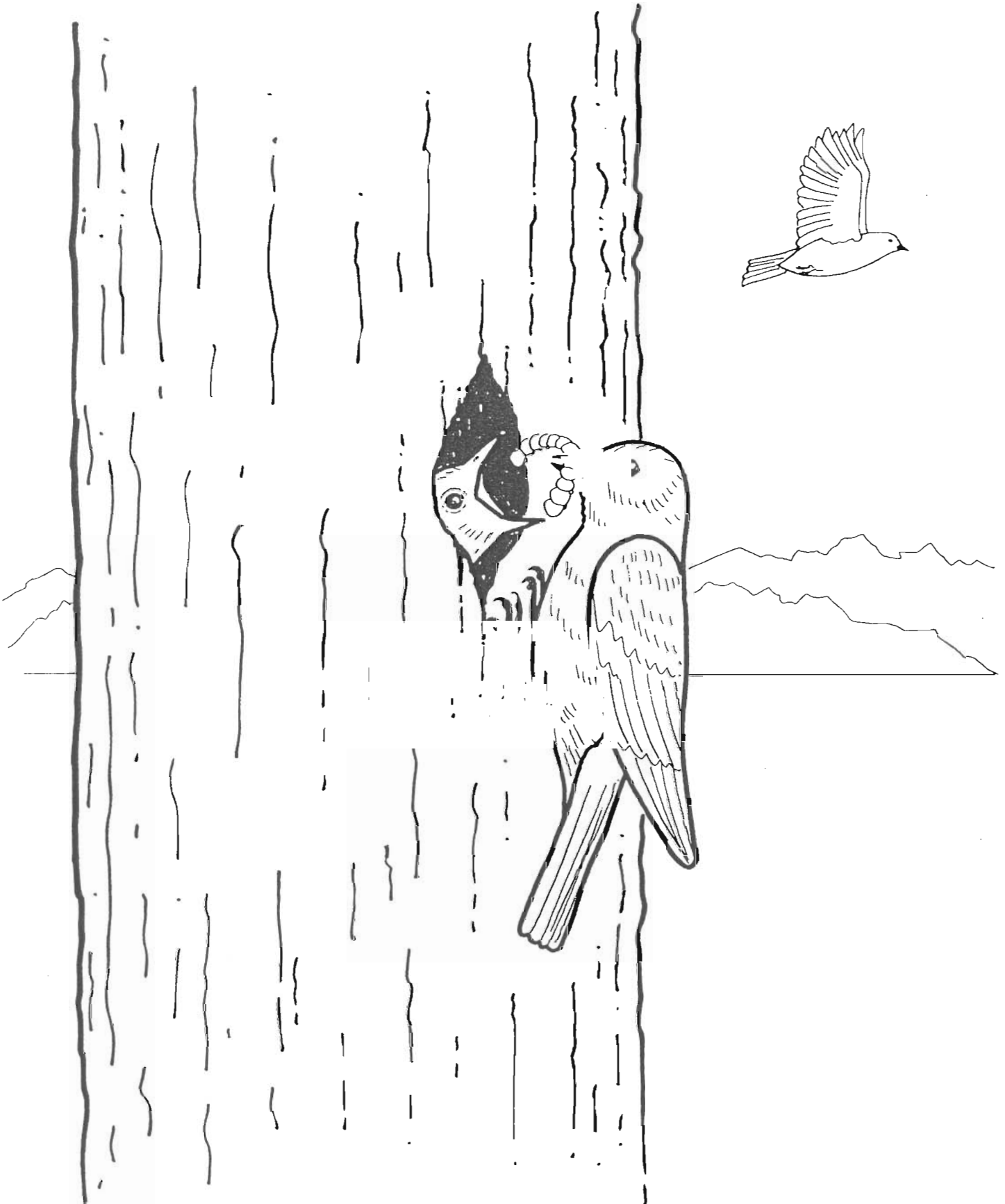

# WESTERN BLUEBIRD

COLORING PAGE

*Sialia mexicana*



# BLUEBIRD MOBILE

## DIRECTIONS:

1. Color
  2. Paste onto heavy paper.
  3. Cut out; punch holes at small circles and assemble like the diagram pictured below.
- NOTE:** May use heavy thread or fishing filament to attach pieces together.

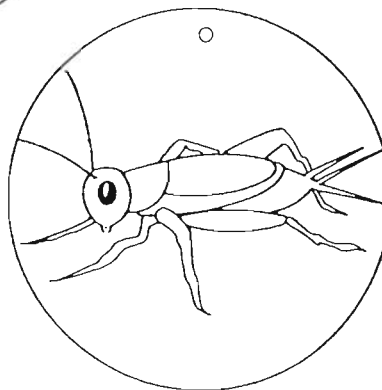
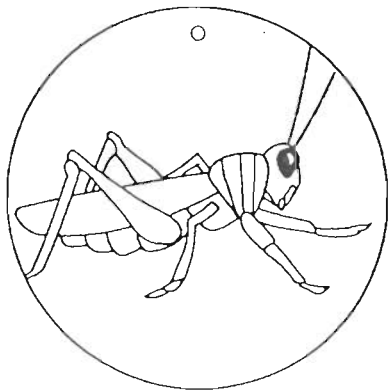
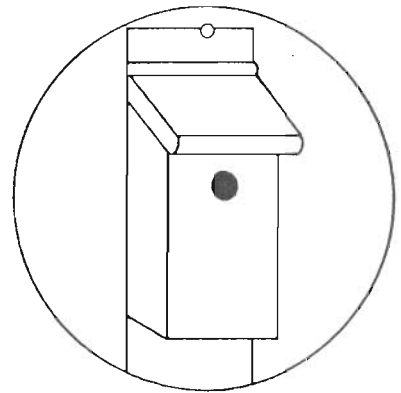
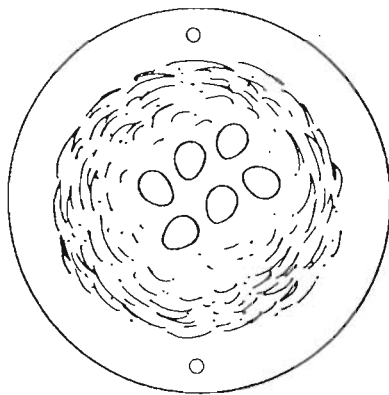
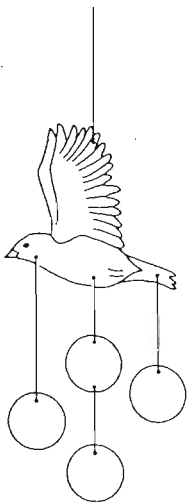
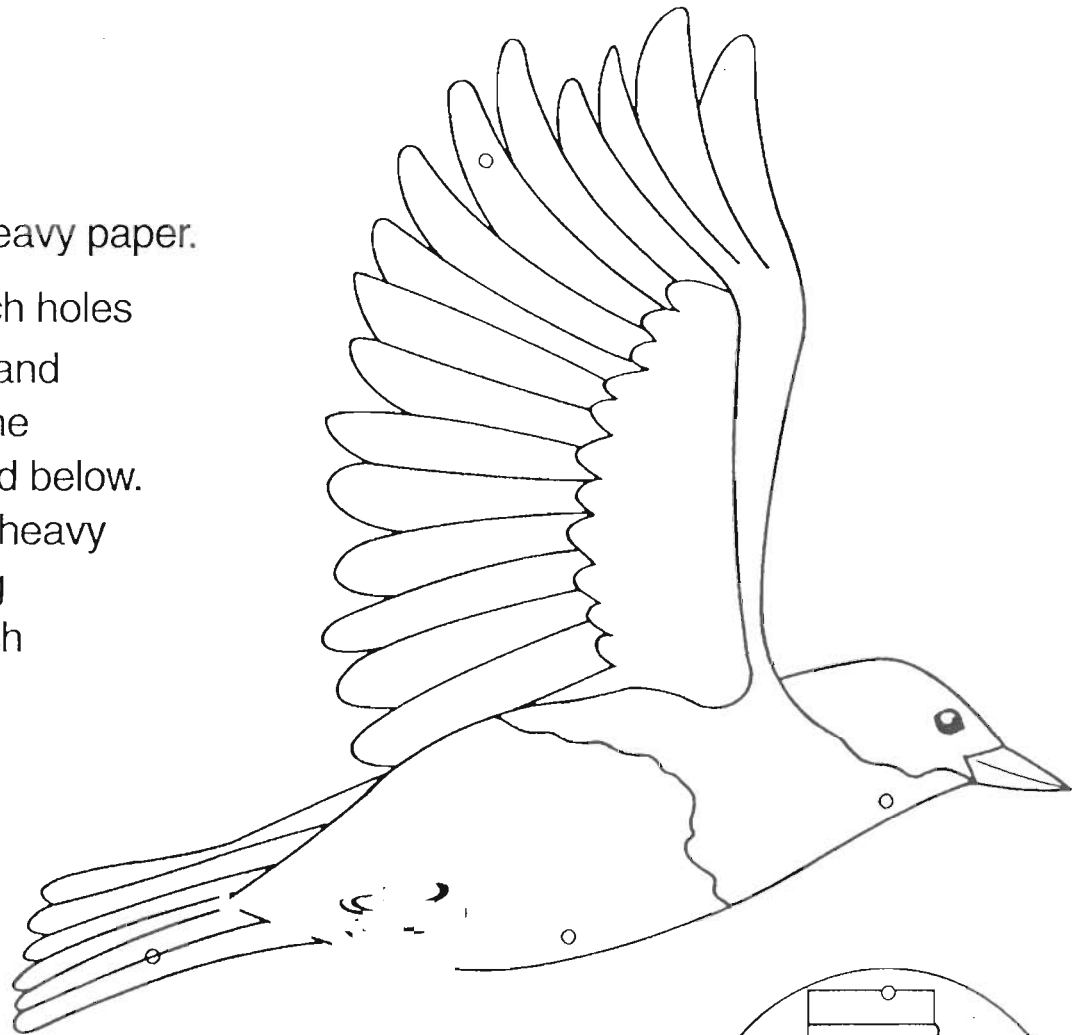

**RIGHT  
SIDE  
OF  
BLUEBIRD  
MOBILE**

# BLUEBIRD MOBILE

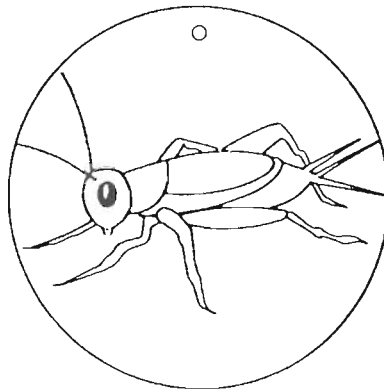
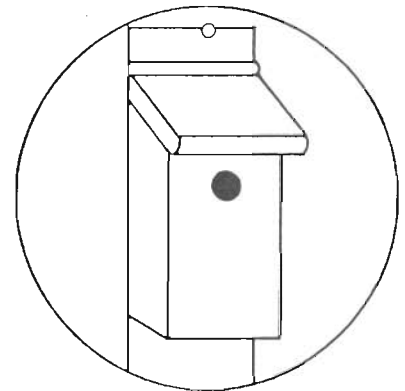
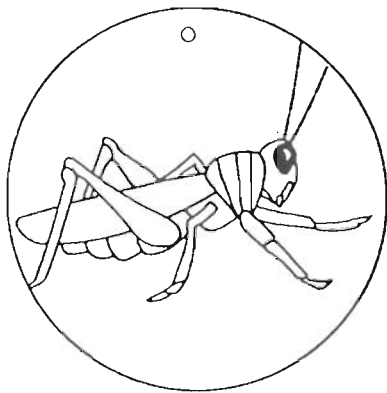
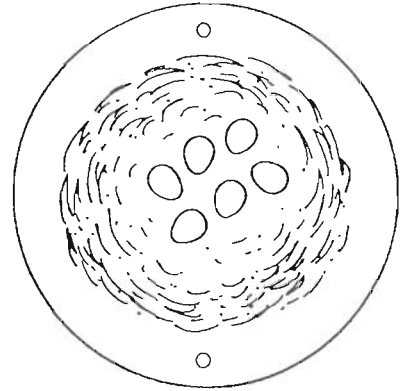
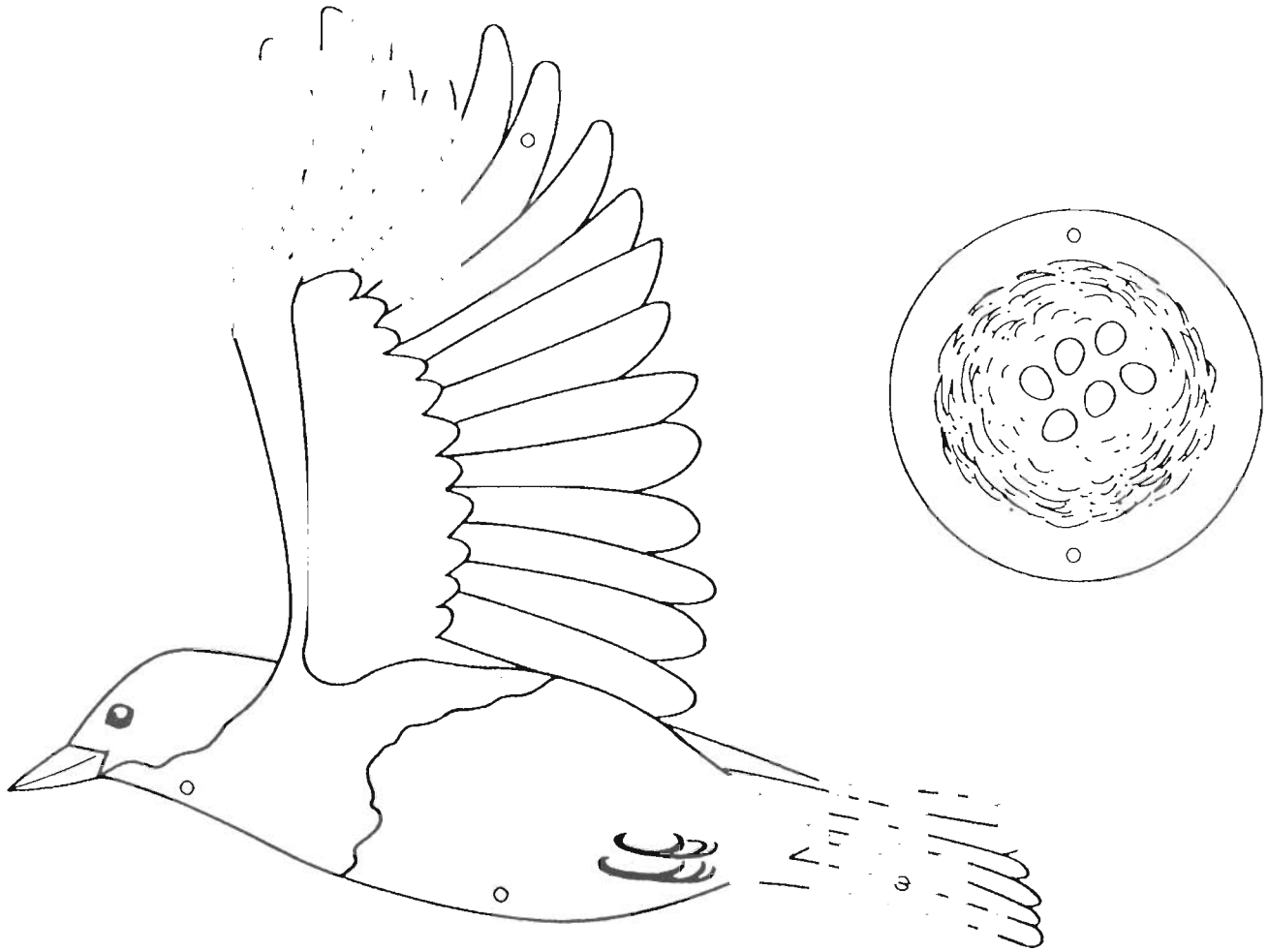

LEFT  
SIDE  
OF  
BLUEBIRD  
MOBILE

# MY FINE-FEATHERED BLUEBIRD FRIEND

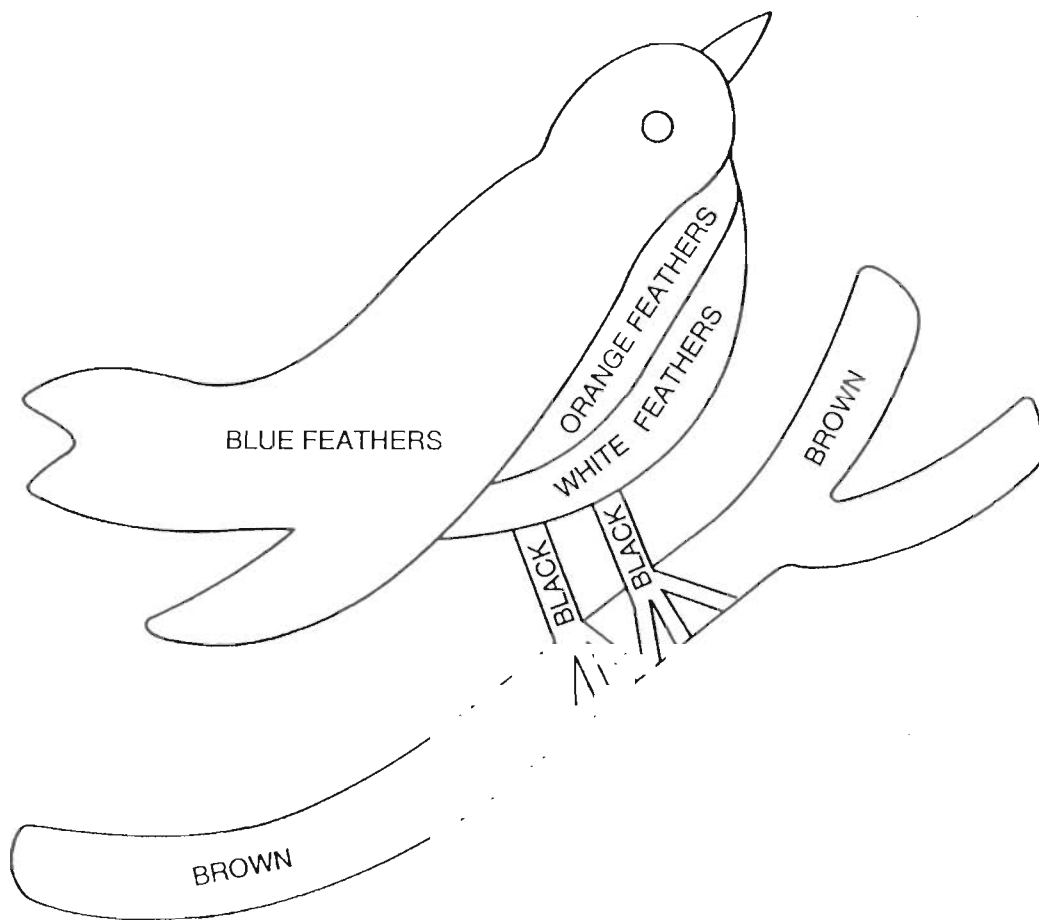

# BLUEBIRD SAND PAINTING

BLUE

DARK GREEN

LIGHT BROWN

MEDIUM BROWN

LIGHT BROWN

MEDIUM BROWN

DARK BROWN

DARK BROWN

DARK BROWN

LIGHT GREEN

MEDIUM BROWN

LIGHT GREEN

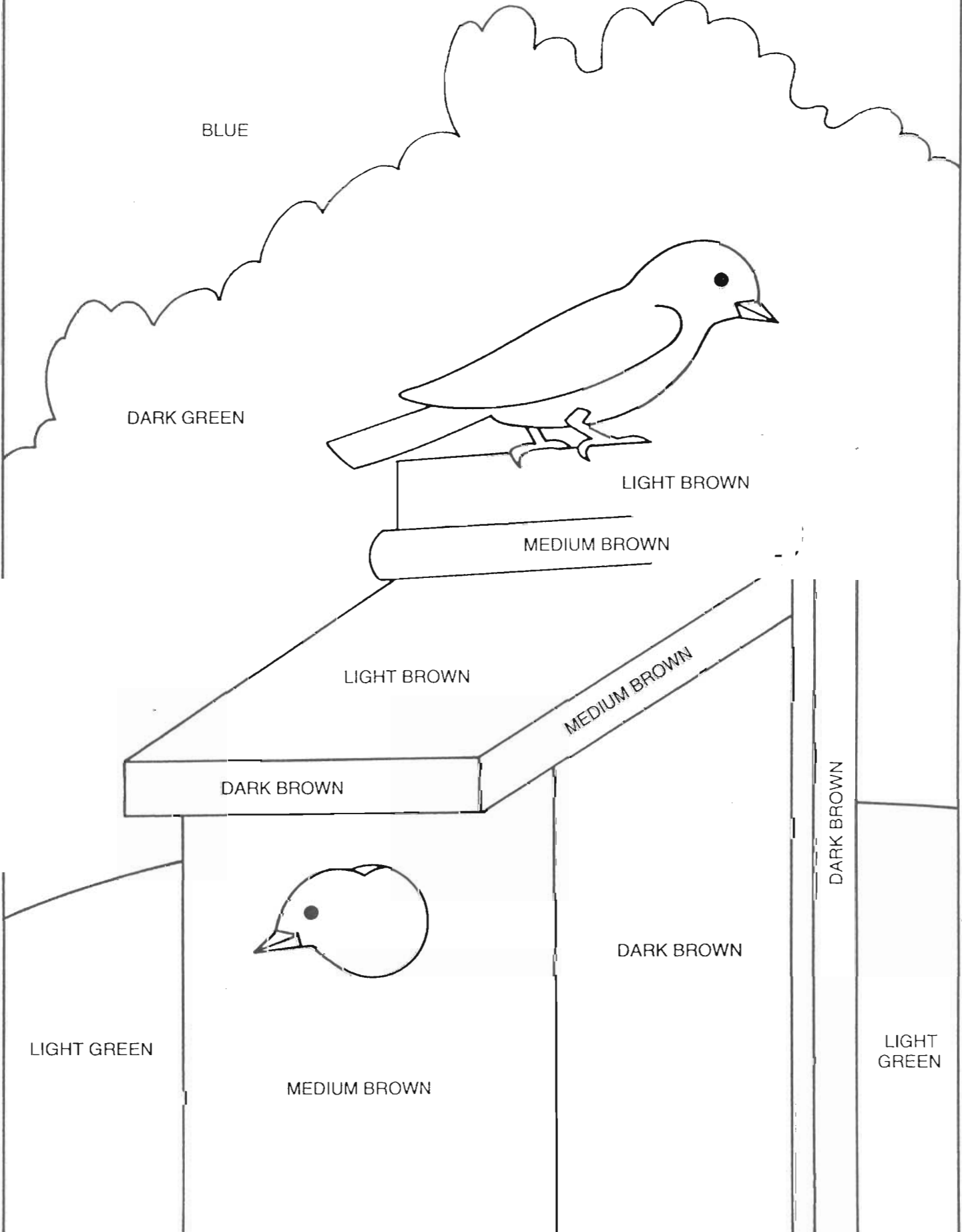

## WORD SEARCH

B A C A D B E E F G H I C A V I T Y N E S T E R  
E F O O F I S T O T K E T L M Q U T A T I B A H  
R E X O L N I G J S R U T A B M N S E F G E E T  
R I N A E P Z A W E H A G W O O D P E C K E R S  
I A S O D R T Y E N G L I O P U A R S D H F O G  
E J K U G L Z A S K I R E L I N O E P M O H M N  
S T A R L I N G T I E E R L O T F D C K U S S T  
M O K T I N W R C O T D I A L A D A N A S I X B  
A S T S N S H A J N O E B W L I C T R E E S I R  
H E L H G E P S E I C E P S I N M O R T S A N D  
C R I A W C A S T D W F A M B Z O R U N P O G M  
A S A P O T V H O B N M A X E R O T Y R A C B P  
D A C K L I B O W E I R L I H Q W E R E R M O B  
W E L D F C F P O P U L A T I O N B O T R U X I  
S E E S V I C P M W E T F I G H L E M S O B E G  
P E R T A D O E B B C D E R N O P L R E W Z I T  
A S R D F E H R S B K L Q U E S R I Y W O L K J  
Z S I R T S E N E R L I N T G H E B A R D I N N  
P Q U A B N A M S L T U L G D W E C K L O I J O  
W E Q R T K U P I L D K E G B E B N T N A S D I  
E A S T E R N M E G R E T B Y Y R O P P A S F T  
F C B E N N S O N T R M R A I S O S B E E M A A  
S W E E D D O N M D T A Y B J R O M K L G U R V  
U Z G F I S I B F C T W E O D N O O C C A R  
O D T I P P G T C V B N J I W R S A T H P F N E  
A F E E V A N O M K L T W E O T R S R I B C O S  
D W O D D R T R A N A W A T I N W Y S D Q E R N  
R V C X E R T I N C U B A T I O N J Y K L G B O  
I B N M L U R N W A S D G H R E E D A K C I H C  
B R T O P E F G W B N J S D N E S T I N G B O X

**FIND WORDS FROM WORD SEARCH LIST--UP, DOWN, FORWARD, BACKWARD, DIAGONALLY!**

## WORD SEARCH LIST

BERRIES  
BIRD  
BLUEBIRD  
BROOD  
CAVITY NESTER  
CHICKADEE  
CONSERVATION  
EASTERN  
EGGS  
ELDERBERRY  
FEEDER  
FLEDGLING  
FOOD  
GRASSHOPPER  
HABITAT  
HOLLY  
HOUSE SPARROW  
INCUBATION  
INSECT  
INSECTICIDES  
MIGRATION  
MONITORING  
MOUNTAIN  
NEST  
NESTING BOX  
POPULATION  
PREDATOR  
RACCOON  
SNAKE  
SPECIES  
SQUIRREL  
STARLING  
SWALLOW  
TRAIL  
WESTERN  
WOODPECKER  
WREN

ANSWERS TO WORD SEARCH

A 20x20 grid of letters with various words circled in black. The grid is as follows:

B	A	C	A	D	B	E	E	F	G	H	I	C	A	V	I	T	Y	N	E	S	T	E	R
E	F	O	O	F	I	S	T	O	T	K	E	T	L	M	Q	U	T	A	T	I	B	A	H
R	E	X	O	L	N	I	G	J	S	R	U	T	A	B	M	N	S	E	F	G	E	E	T
R	I	N	A	E	P	Z	A	W	E	H	A	G	W	O	O	D	P	E	C	K	E	R	S
I	A	S	O	D	R	T	Y	E	N	G	L	I	O	P	U	A	R	S	D	H	F	O	G
E	J	K	U	G	L	Z	A	S	K	I	R	E	L	I	N	O	E	P	M	O	H	M	N
S	T	A	R	L	I	N	G	T	I	E	E	R	L	O	T	F	D	C	K	U	S	S	T
W	O	K	T	I	N	W	R	C	O	T	D	I	A	L	A	D	A	N	A	S	I	X	B
A	S	T	S	N	S	H	A	J	N	O	E	B	W	L	I	C	T	R	E	E	S	I	R
H	E	L	H	G	E	P	S	E	I	C	E	P	S	I	N	M	O	R	T	S	A	N	D
C	R	I	A	W	C	A	S	T	D	W	F	A	M	B	Z	O	R	U	N	P	O	G	M
A	S	A	P	O	T	V	H	O	B	N	M	A	X	E	R	O	T	Y	R	A	C	B	P
D	A	C	K	L	I	B	O	W	E	I	R	L	I	H	Q	W	E	R	E	R	M	O	B
W	E	L	D	F	C	F	P	O	P	U	L	A	T	I	O	N	B	O	T	R	U	X	I
S	E	E	S	V	I	C	P	M	W	E	T	F	I	G	H	L	E	M	S	O	B	E	G
P	E	R	T	A	D	O	E	B	B	C	D	E	R	N	O	P	L	R	E	W	Z	I	T
A	S	R	D	F	E	H	R	S	B	K	L	Q	U	E	S	R	I	Y	W	O	L	K	J
Z	S	I	R	T	S	E	N	E	R	L	I	N	T	G	H	E	B	A	R	D	I	N	N
P	Q	U	A	B	N	A	M	S	L	T	U	L	G	D	W	E	C	K	L	O	I	J	O
W	E	Q	R	T	K	U	P	I	L	D	K	E	G	B	E	B	N	T	N	A	S	D	I
E	A	S	T	E	R	N	M	E	G	R	E	T	B	Y	Y	R	O	P	P	A	S	F	T
F	C	B	E	N	N	S	O	N	T	R	M	R	A	I	S	O	S	B	E	E	M	A	A
S	W	E	E	D	D	O	N	M	D	T	A	Y	B	J	R	O	M	K	L	G	U	R	V
U	Z	G	F	K	I	S	I	B	N	F	C	T	W	E	O	D	N	O	O	C	C	A	R
O	D	T	I	P	P	G	T	C	V	B	N	J	I	W	R	S	A	T	H	P	F	N	E
A	F	E	E	V	A	N	O	M	K	L	T	W	E	O	T	R	S	R	I	B	C	O	S
D	W	O	D	D	R	T	R	A	N	A	W	A	T	I	N	W	Y	S	D	Q	E	R	N
R	V	C	X	E	R	T	I	N	C	U	B	A	T	I	O	N	J	Y	K	L	G	B	O
I	B	N	M	L	U	R	N	W	A	S	D	G	H	R	E	E	D	A	K	C	I	H	C
B	R	T	O	P	E	F	G	W	B	N	J	S	D	N	E	S	T	I	N	G	B	O	X

FIND WORDS FROM WORD SEARCH LIST--UP, DOWN, FORWARD, BACKWARD, DIAGONALLY!

# GAME ONE: MUSICAL NESTING BOXES

## Purpose

This activity teaches participants about the relationship between nesting sites and the population levels of cavity nesters. This is done by playing a modified version of musical chairs in which each chair is symbolic of a nesting site and the students serve as the natural competitors for these nesting sites.

## Organization

Who: Class or group of 10 or more.

Where: Inside.

When: Any time of year.

Time: Approximately one hour.

## Materials:

A set of chairs equal to half the number of participants.

A set of 3x5 cards equal to two and a half times the number of participants.

A data sheet or chalk board for logging population counts.

A record or tape player.

## Preparation Example

For a class of 20, 10 chairs and 50 3x5 cards should be obtained.

The chairs serve as nesting sites and can be set up in a group like musical chairs. Some space between the chairs is recommended.

Divide the cards into two groups of 20 and one of 10. Print the following information on the 3x5 cards as outlined below:

### First group of 20

....On 10 (or half of the cards) print SAFE NEST

....On 10 (or half of the cards) print UNSAFE NEST

### Second group of 20

....On 10 (or half of the cards) print BLUEBIRD

....On 10 (or half of the cards) print a random choice of competitors: SNAKE, RACCOON, STARLING, or SPARROW.

### Third group of 10

....On all of the cards print SAFE NEST

The exact number of cards and chairs will vary according to the actual size of the group.

## Directions

1. Before playing the game lead the group in a discussion of bluebirds and other cavity nesters. Emphasize how the loss of places to nest and competition from other birds and predators has caused a decline in the number of bluebirds. Also explain how some places are safer for bluebirds to nest than others, including specially designed bird boxes made by people. Make sure the students understand that other animals compete with bluebirds and that some places protect bluebirds from these animals and others do not. The level of this discussion should be determined by the age of the group.
2. To start the game, ask someone to shuffle the nest cards and lay one face down on each chair. No one should look at the cards.
3. Next, someone should shuffle the second group of cards and give one to each participant. The students can look at his/her cards.
4. Each complete round of this activity can be treated like a year. It is now springtime and each player who received a BLUEBIRD card should seek a place to nest. If available, play some springlike music during this time. Tell the participants to play their parts, flapping wings, etc. When the music stops, each BLUEBIRD should select the nest closest to it. At first there should be a nest for each bird. BLUEBIRDS should not look at the card on the chairs.
5. After the BLUEBIRDS have found a nest, the COMPETITORS, those who received a card other than BLUEBIRD, should begin to prowl. Again, suggest that everyone plays his part. Snakes should slither, birds circle, raccoons creep. Play some menacing music at this time, if available. When the music stops, the COMPETITORS should choose the nest closest to each of them.

## GAME ONE: MUSICAL NESTING BOXES (continued)

At this time the players should look at what is written on the card in the nest. If it is a SAFE NEST then the BLUEBIRD gets to stay. If it is an UNSAFE NEST the competitor gets the chair.

7. Play the game one or two more rounds, shuffling and replacing the nest cards each time. Also redeal the second deck, so players can get an opportunity to be different characters. At the end of each round, total the number of BLUEBIRDS and SAFE NESTS. These numbers can be written on a chalk board for everyone to see. The players should quickly notice that when there are more safe places to nest, more bluebirds survive.
8. Now you can show the effects of habitat destruction by beginning to remove chairs between each round. With large groups, more than one chair can be removed between rounds to save time. As with musical chairs, those bluebirds that do not find a nest when the music stops are out of that round. Reducing the number of chairs will begin to reduce the number of safe nests and the number of BLUEBIRDS that survive each round. Play enough rounds to reduce the number of chairs to a point where no, or almost no, BLUEBIRDS survive. Explain that this is the situation in many areas.

**IMPORTANT:** For every chair removed after the first round, remove one competitor card and one bluebird card from the second deck before shuffling and dealing. This will keep the number of each group at one greater than the available nests/chairs. Make sure, those players left out for one round get a card the next time to keep everyone involved.

9. Now demonstrate how people can help with a bluebird trail. Replace all the chairs and take the third group of cards with SAFE NEST written on each. Have someone place the cards on each chair without looking at them. Play the game one more time with everyone. At the end of this round, the COMPETITORS will get a surprise when every nest turns out to be safe and all the bluebirds survive.

# GAME TWO: ANSWERS FIRST, QUESTIONS AFTERWARDS

## Purpose

This activity is a combined individual and group lesson to expand vocabulary by having students write questions about terms after they are familiar with the educational package. It is intended for somewhat older and more advanced students. It can be conducted in one of three different versions depending on your group.

## Organization

Who: Any size group

Where: Inside

When: Any time of the year

Time: Approximately one hour

## Materials

A prepared list of answers for each participant

Paper and pencils for each participant

## Directions

1. Hand out copies of the answers to each student. Tell them to write an appropriate question for each answer provided.

### Example:

If the answer provided is      Insects

A good question would be      What do bluebirds eat in the summer?

2. Give the students an adequate amount of time to write questions for the answers on the list. The amount of time required will vary with the reading level and age of the participants.
3. Below are the three different approaches that can be taken with this activity.

### Version One:

In this version, simply collect the papers and grade them for accuracy and thoroughness.

### Version Two:

In this version, you will take the role of host. The host chooses a student from the group and reads an answer from the list. The student will read his/her question. You as master of ceremonies and judge can accept the answer, ask the student to be more specific, or reject the answer and move on to a different student. In this version, the class is all on the same team and will succeed by keeping the number of wrong questions to a minimum.

### Version Three:

This final version is much like the second, except the class should be divided into two groups. In this version, when a student on one team misses a question, a student on the other team gets a chance to read a question. This process is continued until someone reads an acceptable question. The winning side is the one with the most correct questions.

4. When choosing students to read questions for the answers, be sure to get everyone involved. This can be done by moving through the group in some established order, i.e., down or across a row. With large groups, you can go through the list of answers more than once, because there can easily be more than one question written about a particular term. Feel free to pause and discuss an answer with the group. Debating the acceptability of an answer is a great way to learn.

## FURTHER ACTIVITIES

The following ideas are suggestions for continuing studies in bluebird ecology and effective conservation which can serve to further supplement this package.

Have your students look for songs, greeting cards, stories, and poems about bluebirds and share them with the class.

Have your students do some creative writing of their own and share it with the class.

Have your students set up an exhibit or display for a science fair or environmental expo that shows their conservation efforts in constructing trails and habitats and how the bluebird population has been increased.

Encourage your students to develop an interest in other birds. Visit a nature center to learn more about all the birds in the local area.

## BIBLIOGRAPHY

Harrison, Colin. *Nests, Eggs and Nestlings of North American Birds*. Great Britain: William Collins Sons & Company Limited. Glasgow, 1978.

Stokes, Donald and Lillian. *The Bluebird Book*. Boston: Little, Brown Company, 1991.

Zeleny, Lawrence. *The Bluebird: How You Can Help Its Fight For Survival*. Bloomington: Indiana University Press, 1976.

## RESOURCES AVAILABLE FROM THE NORTH AMERICAN BLUEBIRD SOCIETY

### BOOKS

*The Bluebird Book*. Stokes, Donald and Lillian. Little, Brown & Company. Boston, 1991.

*The Bluebird Monitor's Guide*. Berger, Kridler, Griggs. Harper Collins. New York, 2001.

*Bluebird Trails: A Guide to Success*. Scriven, Dorene. Bluebird Recovery Program. Minneapolis, 1999.

*Enjoying Bluebirds More*. Zickefoose, Julie. Birdwatcher's Digest Press. Marietta, OH, 1993.

*Mountain Bluebird Trail Monitoring Guide*. Pearman, Myrna. Canada: Red Deer River Naturalists. Red Deer, Manitoba, 2002.

### POWERPOINT PROGRAM

A program consisting of 80 colored images prepared by the North American Bluebird Society. Photos include bluebird species, other cavity nesting bird species, habitat, nesting, monitoring, predators, nest box mounting. Contact NABS to have the file emailed to you.

### VIDEO

*Bluebird Basics: Getting Started With Bluebirds*. Don & Lillian Stokes created this 15-minute video in cooperation with the North American Bluebird Society. The video is available through the NABS office or the on-line catalog.

For more information about these and other products, please contact the North American Bluebird Society, Inc., P.O. Box 43, Miamiville, OH 45147.

**website: [www.nabluebirdsociety.org](http://www.nabluebirdsociety.org)**



# Mealworm Ranch

An experiment in scientific observation

You have probably heard about caterpillars turning into butterflies or tadpoles turning into frogs. You may have even heard about frogs turning into princes, but that happens only in fairy tales. A lot of animals start life in one form and change into a completely different shape when they become adults. Scientists call this process metamorphosis (met-a-MORF-a-sis).

Mealworm Ranch is a project that will let you see first-hand how metamorphosis works.

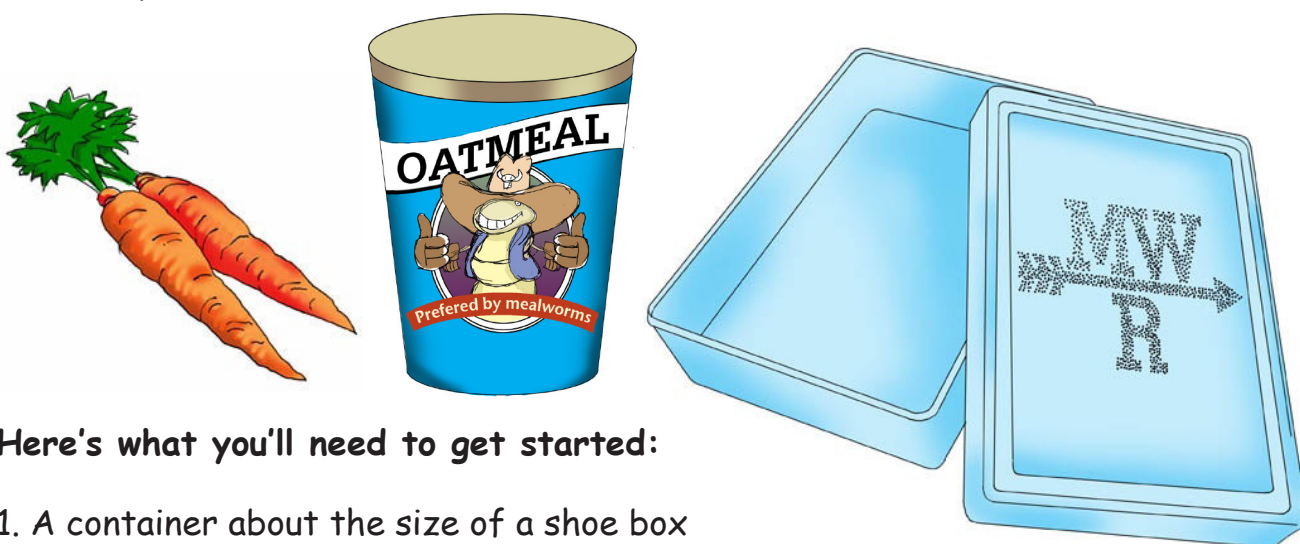

**Here's what you'll need to get started:**

1. A container about the size of a shoe box
2. Oatmeal. That's right oatmeal.
3. One or two carrots.
4. A dozen or so mealworms, which can be purchased inexpensively at any pet store.
5. A notebook so you can record your observations as the mealworms go through metamorphosis.

Note: mealworms are clean and harmless, so it's OK to pick them up gently with your fingers.

## Making a habitat for your experiment:

1. Punch a few holes in the top of the container for air.
2. Dump the oatmeal in the container so the caterpillars have something to eat.
3. Place the carrots in the container so the mealies will have some water. Carrots are full of water, so replace them if they dry out.
4. Place the mealworms in the container. Remove any that are dark brown or black.
5. Put the lid on the box. Mealworms are good climbers, so you should keep the lid on unless you are actually watching them.

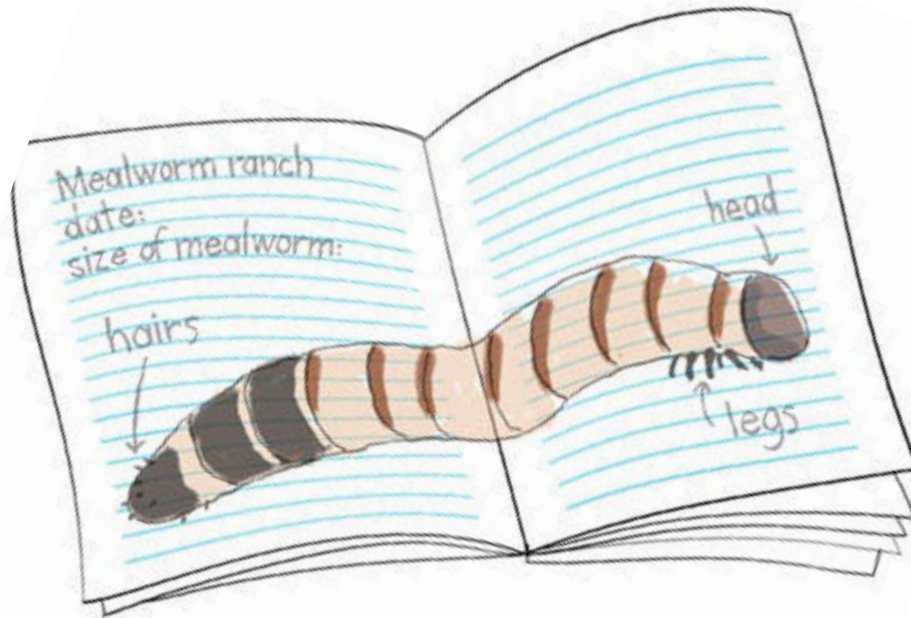

Now you are ready make some notes in your notebook. You might want to draw what these guys look like the first day. You might even write some notes about what you see. For example,

What color are the mealworms?  
How long are they?  
How many legs do they have?  
Do they all seem to have the same number of segments?  
What happens when the mealworms are put on top of the oatmeal?  
How are they moving?  
Do they get along with each other?

Do they make noise?  
Where do they prefer to live?

You can think of more questions and write them down to see if you can find the answers.

Keep checking each day to see if anything has changed. Can you tell what they are eating? Are they growing? Write down any changes you find.

Keep watching. Write and draw in your notebook often. You are going to be surprised when you see the results.

# Save Animal Tracks as Plaster Casts



## What kind of wild animals live near your house?

There are more than rabbits and squirrels, for sure. You might be surprised to find out how many kinds of critters live nearby. With a little detective work, this project will help you discover where some of them live. Also, you will learn how to make plaster casts of their footprints so you can start a collection of their tracks. It's simple and fun.



### Here's what you will need

A one- or two-pound bag or box of plaster of Paris. This is a powder that looks like flour. You can buy plaster of Paris at the hardware store. It is not expensive.

A mixing bowl - a small plastic container such as Tupperware or a plastic cereal bowl. Actually you can use anything that will hold one or two cups of water without leaking, but plastic is reusable and easier to clean. You will be mixing the plaster with water, so it is also better to have something shallow and wide rather than something tall and narrow.

A bottle of water. A 16-ounce plastic soda bottle works great.

An old spoon.

A 2-liter soda bottle cut into 2 inch sections.

A few sheets of newspaper to wrap the track cast.

A bag or knapsack to put all of this stuff in.

Oh yeah, old shoes and clothes that you can get muddy in.

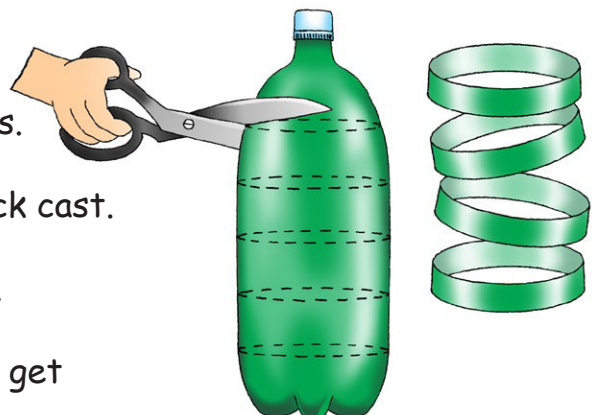

## Let the detective work begin

Look for tracks on wet ground and soft mud. The best place to look is where animals go to drink water. The bank of a creek, stream, river, pond, or lake is a great place to start. Sandbars are good places, too. The edges of mud puddles shouldn't be overlooked.

## How to make a plaster cast

Once you have found a good clean track that you want to keep, gently clear away any debris around the track. Remove any leaves, small stones or twigs without disturbing the track.

Place one soda bottle ring around the track so that the track is centered, and press it about 1/2 inch into the ground. This makes a sturdy circular wall that will keep the plaster from running out.

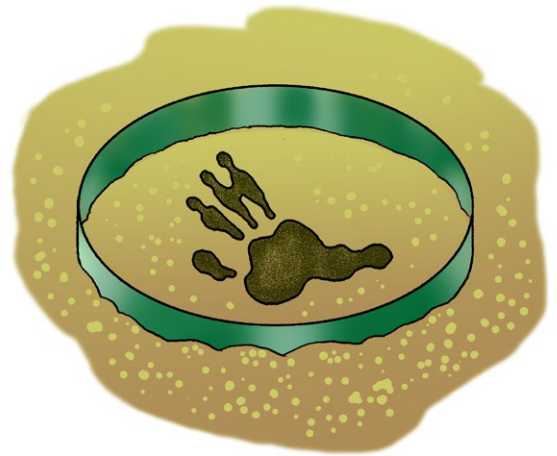

## Mix up some plaster

Pour about a cup of water into your mixing bowl.

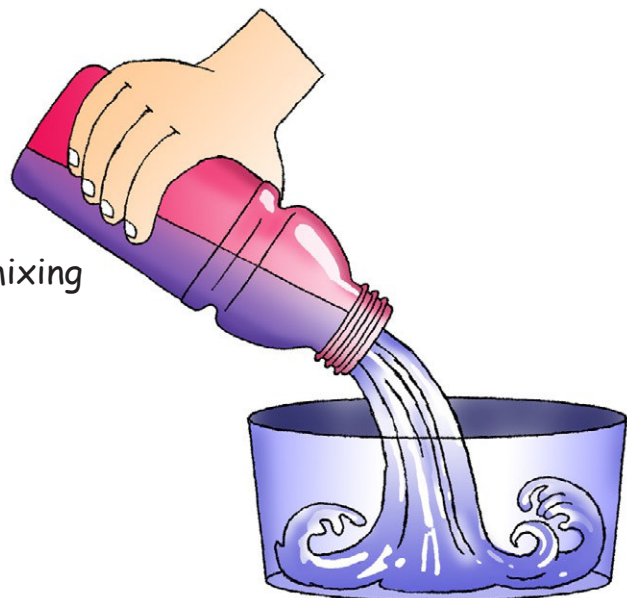

Follow the directions that came with the plaster.

If you don't have instructions, here is how we do it in the field: carefully begin sprinkling some of the plaster into the water. When the plaster looks like the top of a volcano and is about 1/2 inch taller than the water, stop. (See drawing. It's worth a thousand words.) Let it sit for a minute or two so that the plaster absorbs some of the water.



Next, begin slowly (slowly is the magic word) stirring the plaster and water with your spoon until it is creamy like pancake batter. Here is another hint: you don't want to get air bubbles into the plaster mix. They take away some of the detail of the track. Don't whip the mix. Just stir it gently until it is evenly mixed and has no lumps.

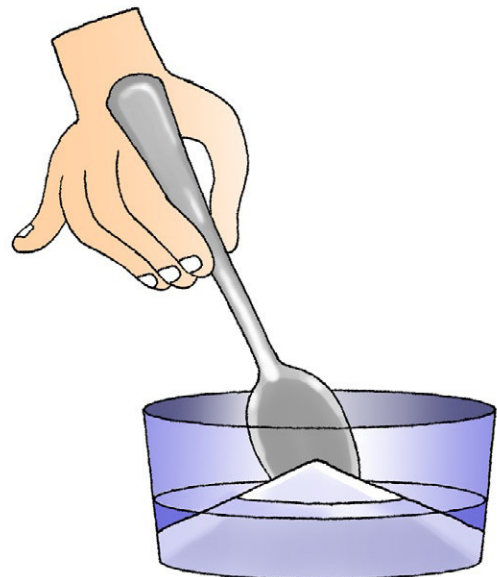

Gently tap the bottom of your mixing bowl on a rock or a fallen tree trunk to remove any air bubbles. As you tap you will see bubbles come to the top. Aren't you glad you didn't whip the plaster? Keep tapping until the bubbles stop coming up.

Now you are ready to pour the plaster into the circle you made earlier. Do not pour the plaster directly on the track. It might ruin it. Instead, pour to the side of the track and let it run into the track. Fill the circle to the top.

This plaster thing you have just made is called a cast. It needs to harden for at least 30 minutes. An hour is better. Even after an hour, the cast will still be soft and will easily break if handled roughly. This is a good time to look for more tracks. Can you find any bird tracks? How about snail tracks?

When the time is up, it is time to remove the cast. Start removing the mud 4 or 5 inches outside of the cast. Next dig away the mud below the cast. Carefully lift up the cast. If there is any resistance, stop. Dig out some more mud. Do not try to pry the cast out with a spoon or a stick. It will crack. Lift it out gently with your hands.

Wrap the cast in newspaper to protect it on the trip home. It is still very fragile. It will be for about two more days. When plaster is drying it feels warm to the touch. The cast will be ready to clean after it feels cool to the touch.

Then you can paint it if you like.

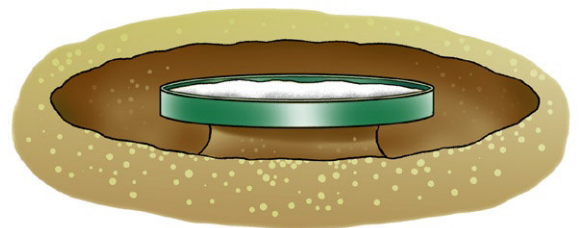

# Animal Tracks Reference Guide

See if you can match your animal track casts to one of these common animals:



F

Dog  $\geq 1/2$ " to 4"

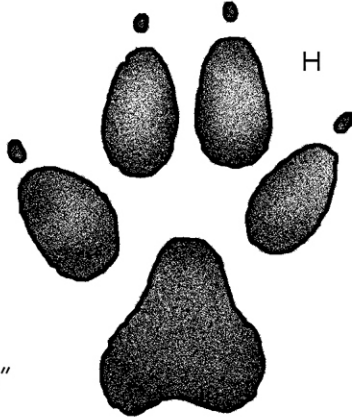

H

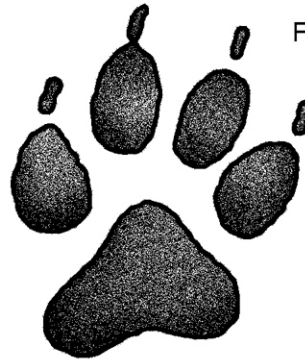

F

Coyote  
front  $\geq 1/2$ "  
hind  $\geq 1/4$ "



H

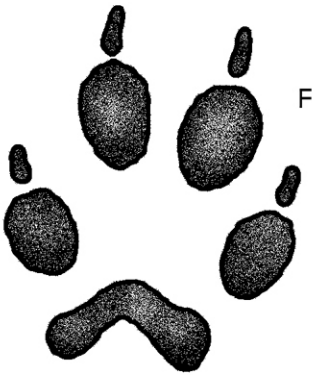

F

Grey Fox  
front 2"  
hind  $1\ 3/4$ "

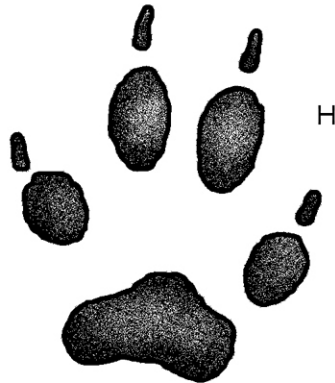

H

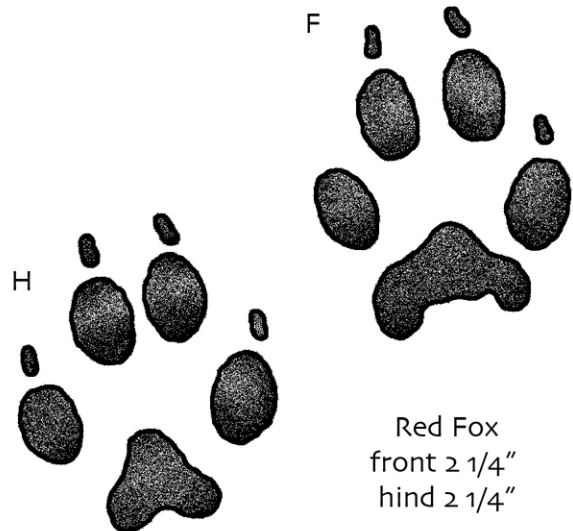

F

Red Fox  
front  $\geq 1/4$ "  
hind  $\geq 1/4$ "

H

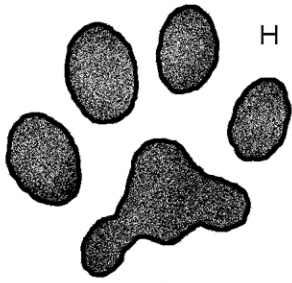

H



F

House Cat 1" to 2"

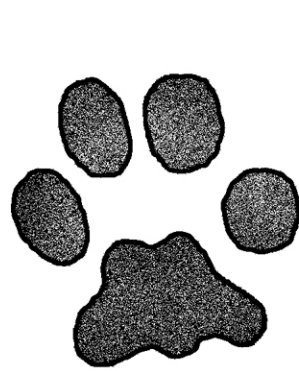

F

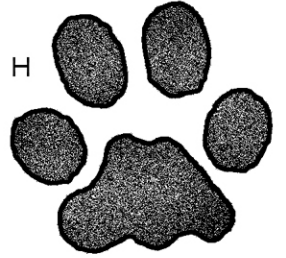

H

Bobcat 1 7/8 "

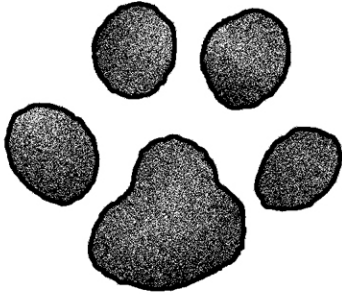

F

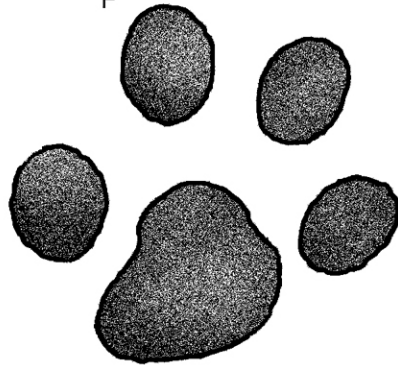

Lynx  
front 4 1/4"  
hind 3"

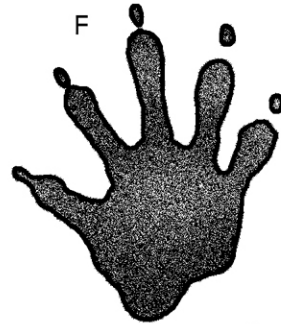

F

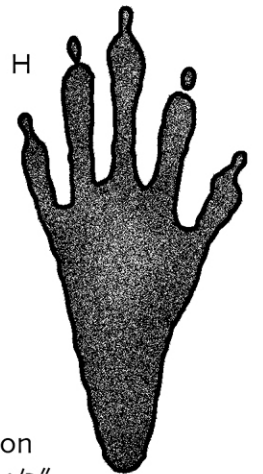

H

Raccoon  
front 2 1/2"  
hind 4"

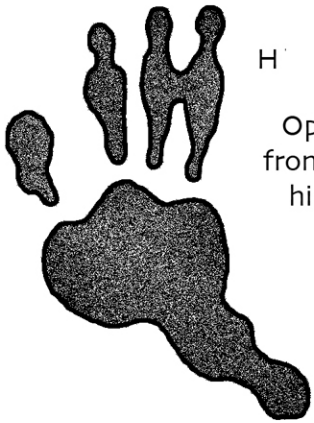

H

Opossm  
front 1 1/4"  
hind 2"

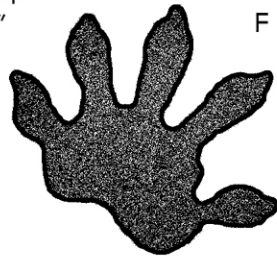

F



H

Grey Squirrel  
front 1 1/2"  
hind 2 1/4



F

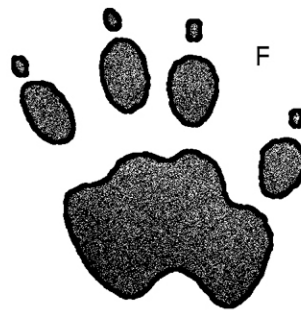

F

Woodchuck  
front 2"  
hind 2 1/4"

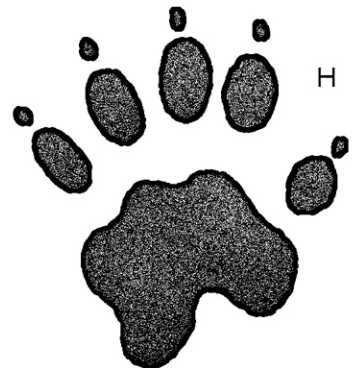

H



H

White-footed Mouse 1/4"



F



Striped Skunk  
front 2"  
hind 2"



Porcupine  
front 2 3/4"  
hind 3 1/4"

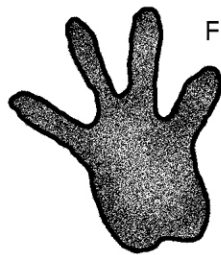

Muskrat  
front 1 1/2"  
hind 2 1/2"

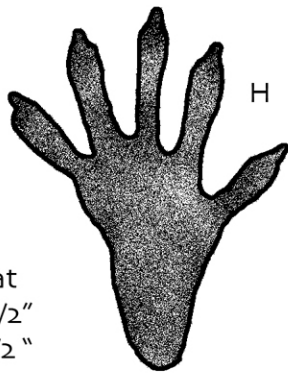

Cottontail Rabbit  
front 1"  
hind 3 1/2"

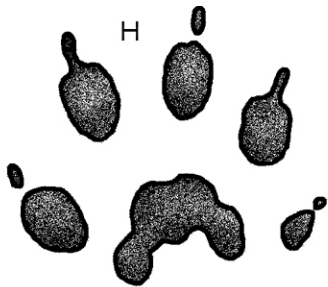

Mink 1"

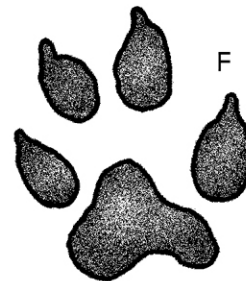
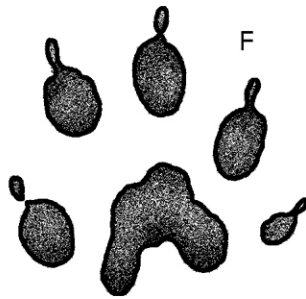

Weasle 1/2" to 1"

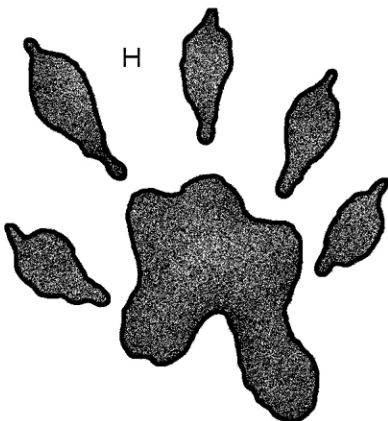
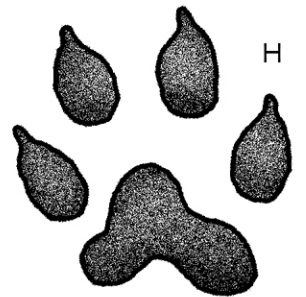

Otter 1 1/2"

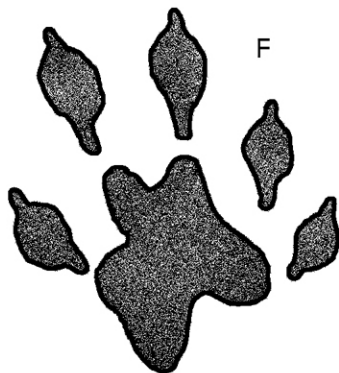

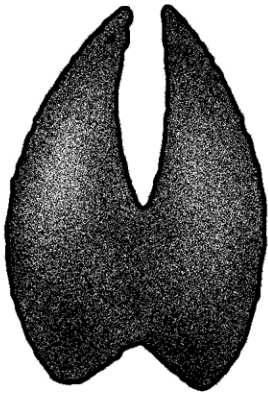

White Tailer Deer  
2 1/2" to 3"

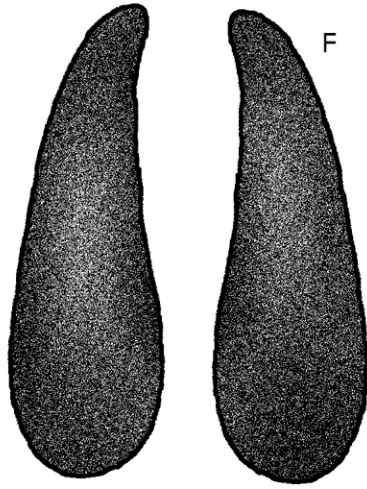

Antelope  
front 1 1/2" x 2 3/4"  
hind 1 7/8" x 3 1/4"

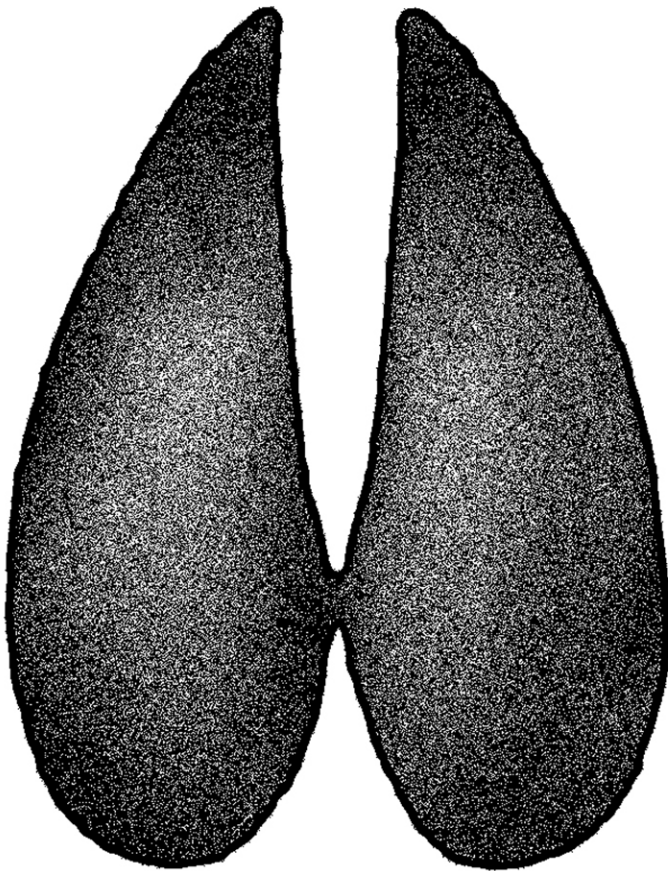
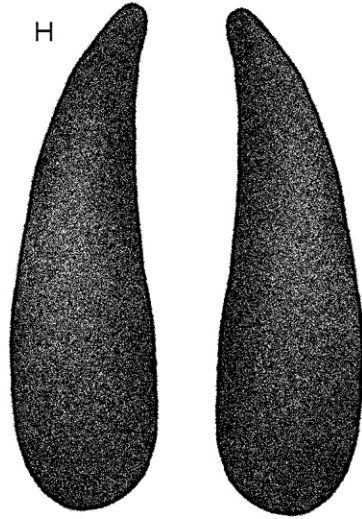

Moose 4 1/2" to 5 1/2"

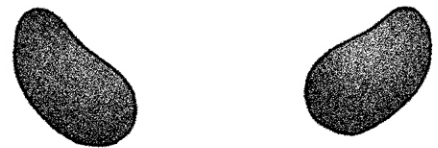
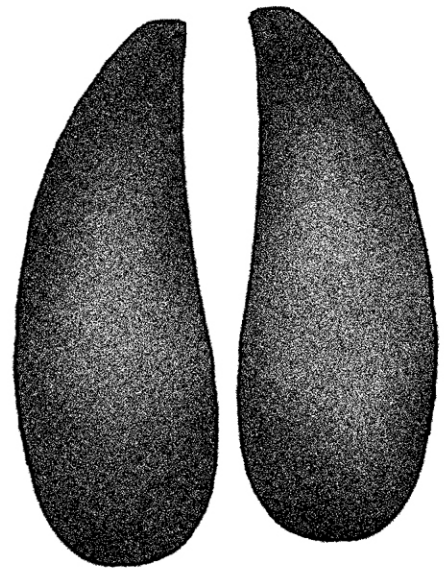

Elk



Brown Bear – Grizzly Bear

Black Bear



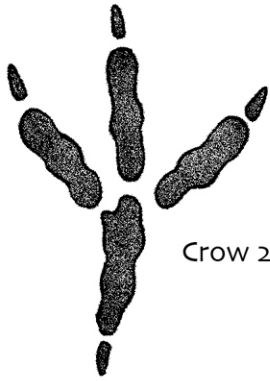

Crow 2 1/2"

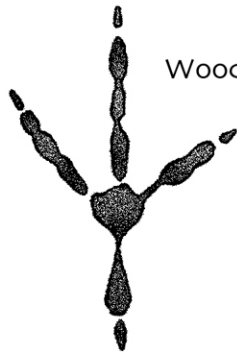

Wood Pigeon



House Sparrow

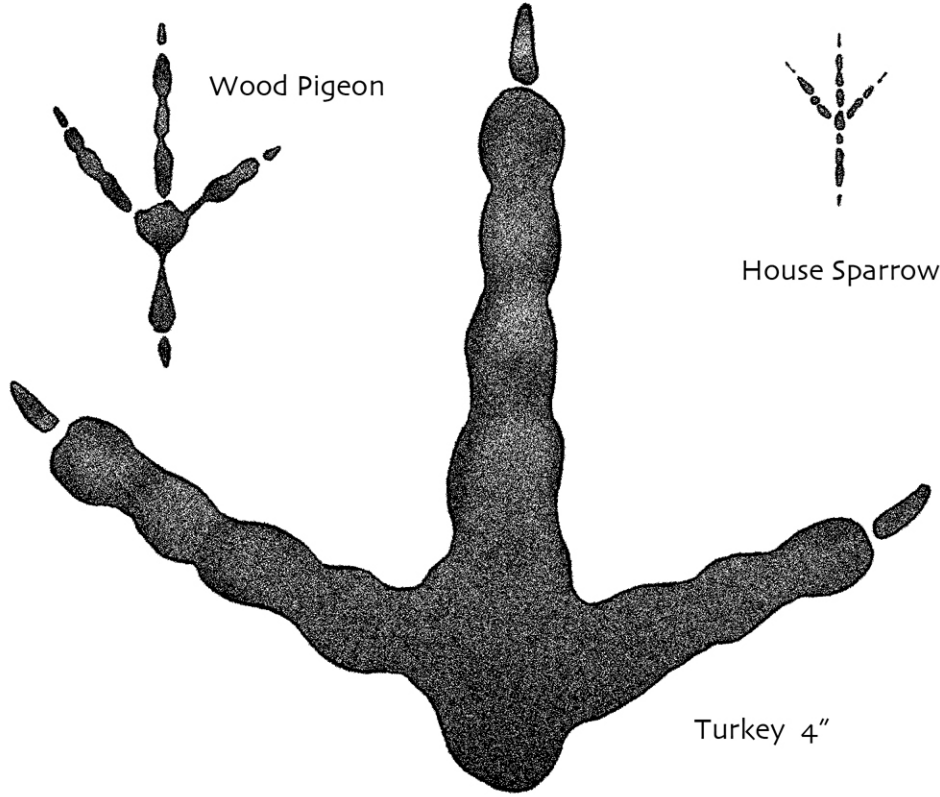

Turkey 4"

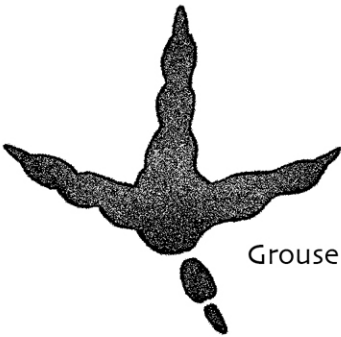

Grouse

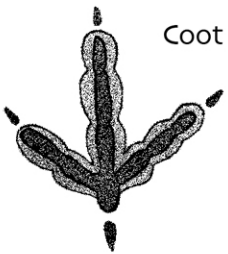

Coot

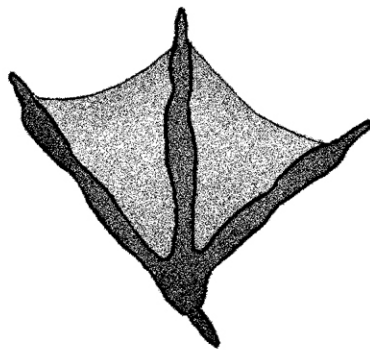

Mallard

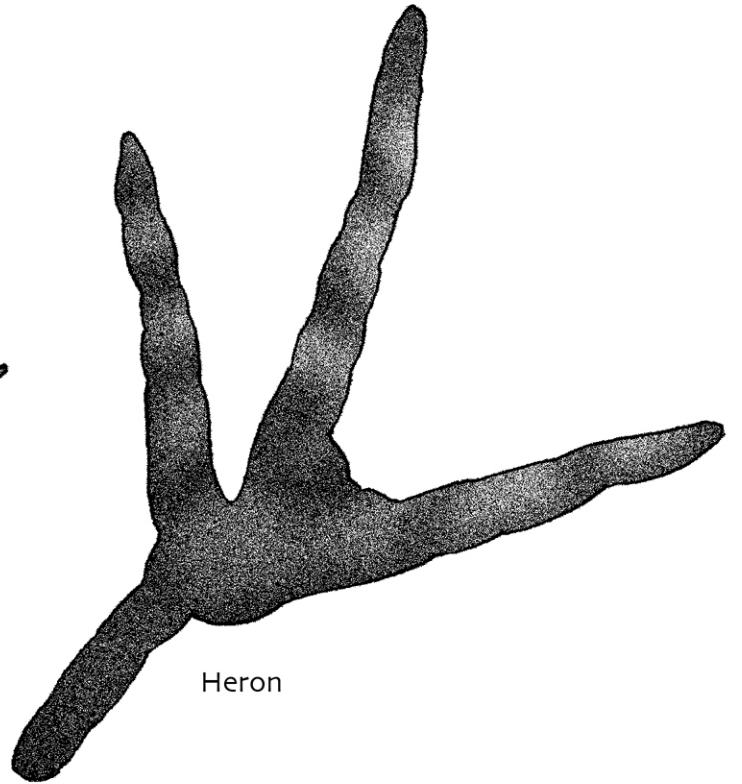

Heron



Killdare

Sea gull

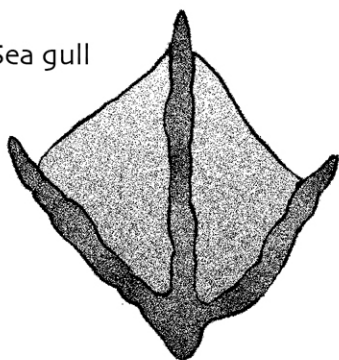

Canada Goose

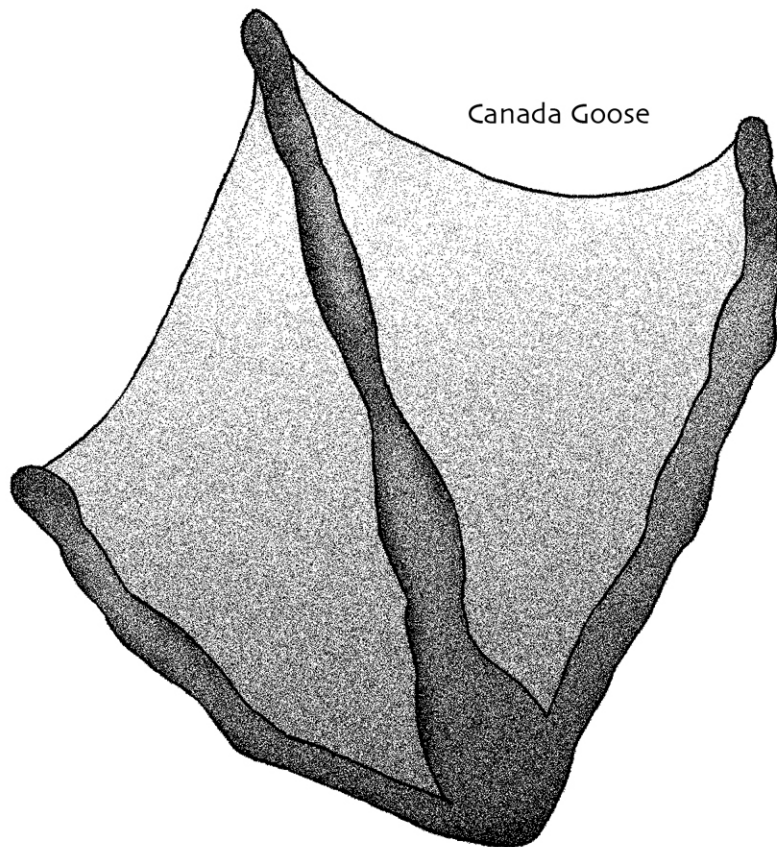

Pelican

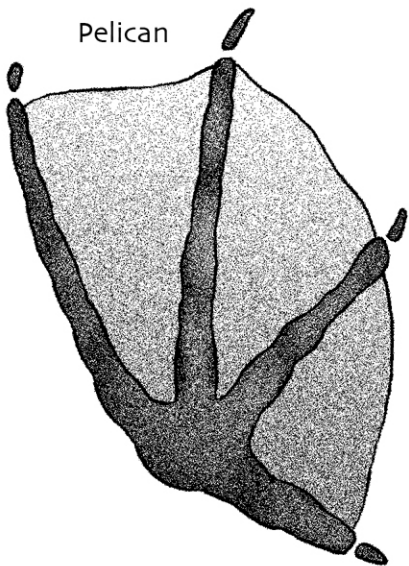

Red-winged blackbird



Cardinal



Roadrunner



Junco



White throated sparrow



Solve the Turtle maze

